



Univerzitet u Beogradu – Građevinski fakultet  
www.grf.bg.ac.rs

---

Studijski program: **Građevinarstvo**

Godina/Semestar: **III godina / V semestar**

Naziv predmeta (šifra): **Teorija betonskih konstrukcija 1**

Nastavnik: **Ivan Ignjatović**

Naslov predavanja: **Torzija grede**

Datum : 27.11.2024.

---

Beograd, 2020.

*Sva autorska prava autora prezentacije i/ili video snimaka su zaštićena. Snimak ili prezentacija se mogu koristiti samo za nastavu na daljinu studenta Građevinskog fakulteta Univerziteta u Beogradu u školskoj 2020/2021 i ne mogu se koristiti za druge svrhe bez pismene saglasnosti autora materijala.*



# Proračun preseka za granične uticaje momenata torzije $T_{Ed}$

## TEORIJSKE OSNOVE

- a)  $T_{Ed} \leq T_{Rd,c}$  - beton ima dovoljnu nosivost na torziju i nisu potrebne ni poprečna ni podužna proračunska armatura (usvaja se samo konstruktivna armatura)
- b)  $T_{Rd,c} < T_{Ed} \leq \min(T_{sw,Rd}, T_{sl,Rd})$  - potrebno je sračunati poprečnu i podužnu armaturu za prihvatanje momenata torzije kojima se poverava deo momenta torzije  $T_{Ed}$
- c)  $T_{Ed} \leq T_{Rd,max}$  - uslov koji uvek mora biti zadovoljen
- $T_{Rd,c}$  - proračunska nosivost elementa pri smicanju bez armature za smicanje
  - $T_{Rd,sw}$  - proračunska vrednost momenta torzije koju može da prihvati poprečna armatura
  - $T_{Rd,sl}$  - proračunska vrednost momenta torzije koju može da prihvati podužna armatura
  - $T_{Rd,max}$  - proračunska vrednost maksimalnog momenta torzije smicanja koju element može da prihvati



# Proračun preseka za granične uticaje momenata torzije $T_{ed}$

## TEORIJSKE OSNOVE

Proračun elemenata u kojima je potrebna proračunska **POPREČNA** i **PODUŽNA** armatura za prihvatanje torzije (glavnih napona zatezanja) zasniva se na **MODELU PROSTORNE REŠETKE**

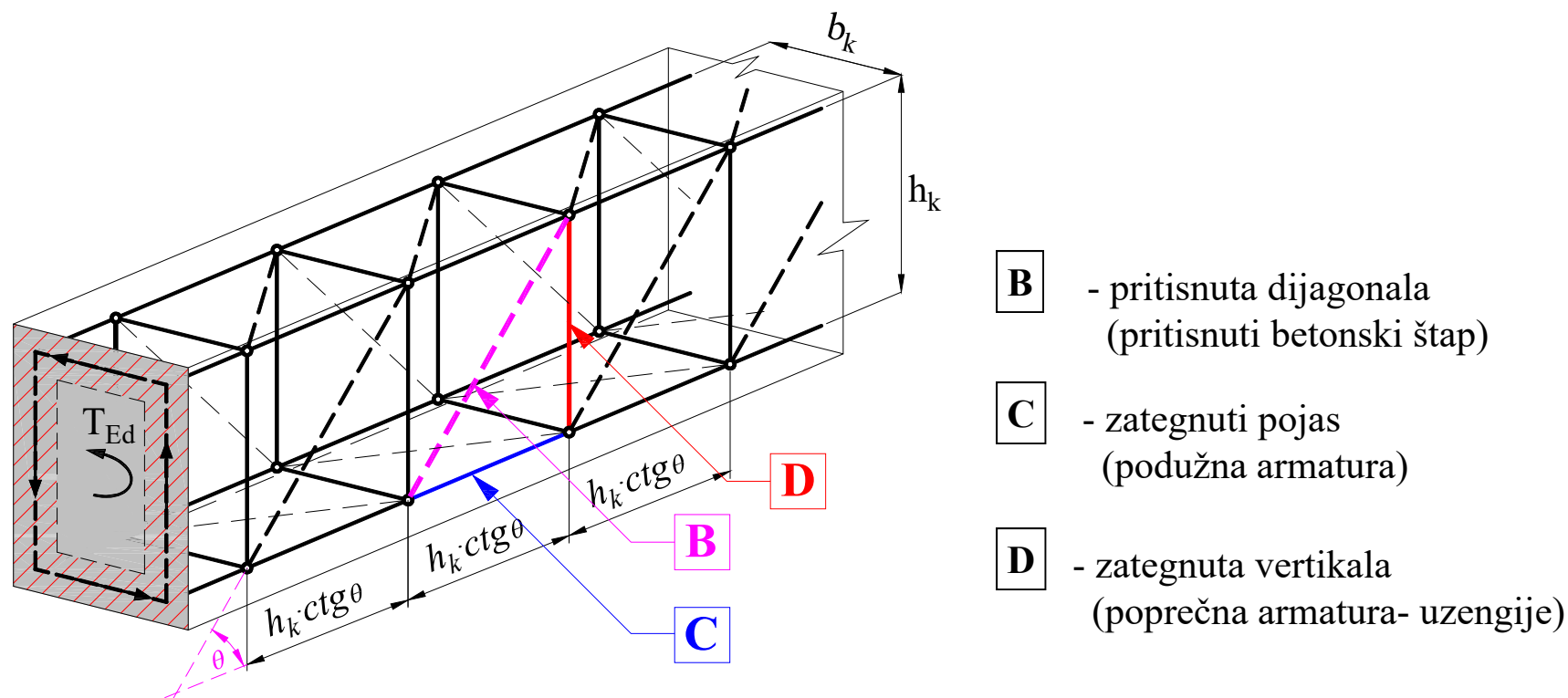

$\alpha$  – ugao između armature za smicanje i podužne ose grede ( $\alpha = 90^\circ$ )

$\theta$  – ugao između pritisnute betonske dijagonale i podužne ose grede ( $22^\circ \leq \theta \leq 45^\circ$ )

# Proračun preseka za granične uticaje transverzalnih sila $V_{Ed}$ momenata torzije $T_{Ed}$ -TEORIJSKE OSNOVE

Uticaje torzije i smicanja je moguće superponirati, pretpostavljajući isti nagib pritisnutih štapova, definisan uglom  $\theta$

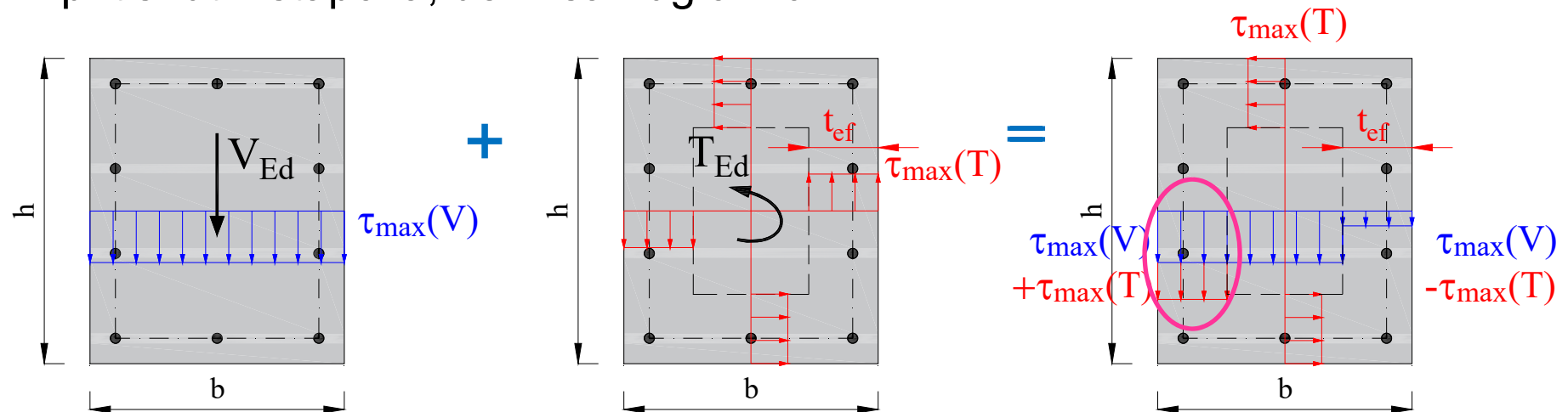

Maksimalna nosivost elementa nije prekoračena ako je zadovoljen uslov:

$$\frac{T_{Ed}}{T_{Rd,max}} + \frac{V_{Ed}}{V_{Rd,max}} \leq 1.0$$

$T_{Rd,max}$  i  $V_{Rd,max}$  su maksimalne nosivosti na dejstvo momenata torzije odnosno transverzalnih sila, respektivno



## Zadatak 26 – TORZIJA

*Dimenzionisati gredni nosač pravougaonog poprečnog preseka ( $b/h=50/60\text{cm}$ ), koji je opterećen momentima torzije  $T_g$  i  $T_q$  usled dejstva stalnog odnosno povremenog opterećenja.*

C30/37 B500B                      XC1       $T_g=50\text{ kNm}$        $T_q=40\text{ kNm}$

$$\text{C30/37} \quad f_{cd} = 0.85 \cdot 30 / 1.5 = 17 \text{ MPa} = 1.7 \text{ kN/cm}^2$$

$$\text{B500 B} \quad f_{yd} = 500 / 1.15 = 435 \text{ MPa} = 43.5 \text{ kN/cm}^2$$



## Zadatak 26 – TORZIJA

1. Proračunske vrednosti uticaja:

Koeficijenti sigurnosti:  $\gamma_G = 1.35$ ,  $\gamma_Q = 1.5$

$$T_{Ed} = \gamma_G \cdot T_g + \gamma_Q \cdot T_q = 1.35 \cdot 50 + 1.5 \cdot 40 = 127.5 \text{ kNm}$$

2. Karakteristike ekvivalentnog tankozidnog preseka:

$$t_{ef} = \max \left\{ \begin{array}{l} \frac{A}{u} = \frac{b \cdot h}{2 \cdot (b + h)} = \frac{50 \cdot 60}{2 \cdot (50 + 60)} = \underline{\underline{13.64 \text{ cm}}} \\ 2 \cdot d_1 = 2 \cdot 5 = 10.0 \text{ cm} \end{array} \right.$$

$$b_k = b - 2 \cdot t_{ef} / 2 = 50 - 2 \cdot 13.636 / 2 = 36.36 \text{ cm}$$

$$h_k = h - 2 \cdot t_{ef} / 2 = 60 - 2 \cdot 13.636 / 2 = 46.36 \text{ cm}$$

$$A_k = b_k \cdot h_k = 36.36 \cdot 46.36 = 1685.65 \text{ cm}^2$$

$$u_k = 2 \cdot (b_k + h_k) = 2 \cdot (36.36 + 46.36) = 165.44 \text{ cm}$$

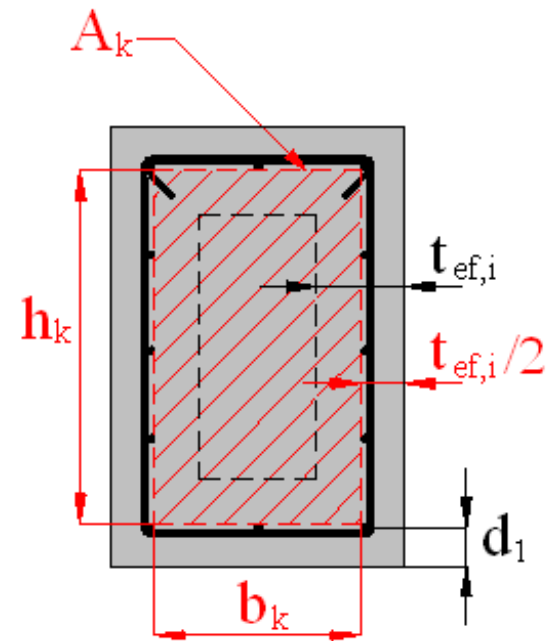

## Zadatak 26 – TORZIJA

3. Sračunavanje momenta torzije pri nastanku prslina,  $T_{c,Rd}$

$$T_{c,Rd} = f_{ctd} \cdot 2 \cdot A_k \cdot t_{ef} = 0.133 \cdot 2 \cdot 1685.65 \cdot 13.64 \cdot 10^{-2} = 61.16 \text{ kNm}$$

$$f_{ctd} = \frac{\alpha_{ct} \cdot f_{ctk,0.05}}{\gamma_c} = \frac{1.0 \cdot 2.0}{1.5} = 1.33 \text{ MPa} = 0.133 \text{ kN / cm}^2$$

TABLICA SA SVOJSTVIMA BETONA  
/ Vidi vežbe 2V /

$$T_{Ed} = 127.5 \text{ kNm} > T_{c,Rd} = 61.16 \text{ kNm} \quad \Rightarrow \quad \text{Potrebna je računaska poprečna i podužna armatura !}$$

4. Maksimalni moment torzije koji presek može da prihvatiti:

$$T_{Rd,max} = 2 \cdot A_k \cdot \alpha_{cw} \cdot v \cdot f_{cd} \cdot t_{ef,i} \cdot \sin \theta \cdot \cos \theta$$

$$\alpha_{cw} = 1.0 \quad , \quad v = 0.6 \cdot (1 - 30 / 250) = 0.528 \quad , \quad \theta = 45^\circ \quad v_1 = 0.6 \cdot \left[ 1 - \frac{f_{ck}}{250} \right]$$

$$T_{Rd,max} = 2 \cdot 1685.65 \cdot 1.0 \cdot 0.528 \cdot 1.7 \cdot 13.64 \cdot \sin 45^\circ \cdot \cos 45^\circ \cdot 10^{-2} = 206.38 \text{ kNm}$$

$$T_{Ed} = 127.5 \text{ kNm} < T_{Rd,max} = 206.38 \text{ kNm}$$





## Zadatak 26 – TORZIJA

5. Minimalna propisana površina poprečne armature:

$$\rho_{w,\min} = 0.08\sqrt{f_{ck}} / f_{yk} = 0.08\sqrt{30} / 500 = 0.000876$$

$$\rho_w = \frac{A_{sw}}{s_w \cdot b \cdot \sin \alpha} = \rho_{w,\min} \Rightarrow \left( \frac{a_{sw}^{(1)}}{s_w} \right)_{\min} = \rho_{w,\min} \cdot b \cdot \sin \alpha$$

$$\left( \frac{a_{sw}^{(1)}}{s_w} \right)_{\min} = 0.000876 \cdot 50 \cdot \sin 90^\circ = 0.0438$$



## Zadatak 26 – TORZIJA

6. Potrebna **površina jednog profila poprečne armature** (uzengija) za prihvatanje momenta torzije jednaka je (za  $\theta = 45^\circ$ ):

$$\frac{a_{sw}}{s_w} = \frac{T_{Ed}}{2 \cdot A_k \cdot f_{ywd} \cdot ctg \theta} = \frac{127.5 \cdot 10^2}{2 \cdot 1685.65 \cdot 43.5 \cdot ctg 45^\circ} = 0.087 > \left( \frac{a_{sw}^{(1)}}{s_w} \right)_{min}$$

$$\left\{ \begin{array}{l} U\emptyset 8 \Rightarrow s_w = \frac{0.503}{0.087} = 5.78 \text{ cm} \\ U\emptyset 10 \Rightarrow s_w = \frac{0.785}{0.087} = 9.03 \text{ cm} \\ U\emptyset 12 \Rightarrow s_w = \frac{1.13}{0.087} = 12.99 \text{ cm} \end{array} \right.$$

*Usvojeno: U $\emptyset$ 10/7,5 (10,5 cm<sup>2</sup>/m)*

7. Ukupna **površina podužne armature** potrebne za prihvatanje momenta torzije (za  $\theta = 45^\circ$ ), jednaka je:

$$A_{sl} = \frac{T_{Ed}}{2 \cdot A_k \cdot f_{yd}} \cdot u_k \cdot ctg \theta = \frac{127.5 \cdot 10^2}{2 \cdot 1685.65 \cdot 43.5} \cdot 165.44 \cdot ctg 45^\circ = 14.39 \text{ cm}^2$$

*Usvojeno: 14 $\emptyset$ 12 (15.8 cm<sup>2</sup>)*



# Zadatak 26a – TORZIJA

**Varijantno rešenje:** Umesto usvajanja, nagib pritisnute dijagonale  $\theta$  računa se iz uslova:

$$T_{Rd,max} = T_{Ed}$$

$$T_{Rd,max} = 2 \cdot A_k \cdot \alpha_{cw} \cdot v \cdot f_{cd} \cdot t_{ef,i} \cdot \sin \theta \cdot \cos \theta = T_{Ed}$$

$$\theta = \frac{1}{2} \cdot \arcsin \frac{T_{Ed}}{A_K \cdot \alpha_{cw} \cdot v \cdot f_{cd} \cdot t_{ef}} = \frac{1}{2} \cdot \arcsin \frac{127.5}{16851 \cdot 1 \cdot 0.528 \cdot 1.7 \cdot 13.64 \cdot 10^{-2}} = 19.1^\circ < 21.8^\circ$$



$$\theta = \theta_{min} = 21.8^\circ$$

$$ctg \theta = 2.5 \quad tg \theta = 0.4$$



## Zadatak 26a – TORZIJA

6a. Potrebna **površina jednog profila poprečne armature** (uzengija) za prihvatanje momenta torzije jednaka je (za  $\theta = 21,8^\circ$ ):

$$\frac{a_{sw}}{s_w} = \frac{T_{Ed}}{2 \cdot A_k \cdot f_{ywd} \cdot \text{ctg}\theta} = \frac{127.5 \cdot 10^2}{2 \cdot 1685.65 \cdot 43.5 \cdot 2.5} = \underline{0.035} < 0.0438 = \left( \frac{a_{sw}^{(1)}}{s_w} \right)_{\min}$$

Usvaja se minimalni procenat armiranja uzengijama, tj.  $\left( \frac{a_{sw}^{(1)}}{s_w} \right)_{\min} = 0.0438$

$$\left\{ \begin{array}{l} U\emptyset 8 \Rightarrow s_w = \frac{0.503}{0.0438} = 11.5 \text{ cm} \\ U\emptyset 10 \Rightarrow s_w = \frac{0.785}{0.0438} = 17.9 \text{ cm} \\ U\emptyset 12 \Rightarrow s_w = \frac{1.13}{0.0438} = 25.8 \text{ cm} \end{array} \right.$$

*Usvojeno: U $\emptyset$ 10/15 (5,23 cm<sup>2</sup>/m)*

7a. Ukupna **površina podužne armature** potrebne za prihvatanje momenata torzije (za  $\theta = 21,8^\circ$ ), jednaka je:

$$A_{sl} = \frac{T_{Ed}}{2 \cdot A_k \cdot f_{yd}} \cdot u_k \cdot \text{ctg}\theta = \frac{127.5 \cdot 10^2}{2 \cdot 1685.65 \cdot 43.5} \cdot 165.44 \cdot 2.5 = 36 \text{ cm}^2$$

*Usvojeno: 12 $\emptyset$ 20 (37,7 cm<sup>2</sup>)*



## Zadatak 26b – TORZIJA

**Varijantno rešenje:** usvajanje nagiba pritisnute dijagonale  $\theta$  u oblasti:

$$21.8^\circ \leq \theta \leq 45^\circ$$

Usvojanje ugla  $\theta$ :  $\theta = 35^\circ$

$$\frac{a_{sw}}{s_w} = \frac{127.5 \cdot 10^2}{2 \cdot 1685.65 \cdot 435 \cdot \text{ctg}35^\circ} = 0.0609$$

6b.  Usvojeno: UØ10/12,5 (6,28 cm<sup>2</sup>/m)

$$7b. A_{sl} = \frac{127.5 \cdot 10^2}{2 \cdot 1685.65 \cdot 43.478} \cdot 165.44 \cdot \text{ctg}35^\circ = 20.55 \text{ cm}^2$$

Usvojeno: 14Ø14 (21,56 cm<sup>2</sup>)



# Zadatak 26 – TORZIJA

Poprečni presezi:

Oblik uzengije!

$\theta = 21,8^\circ$

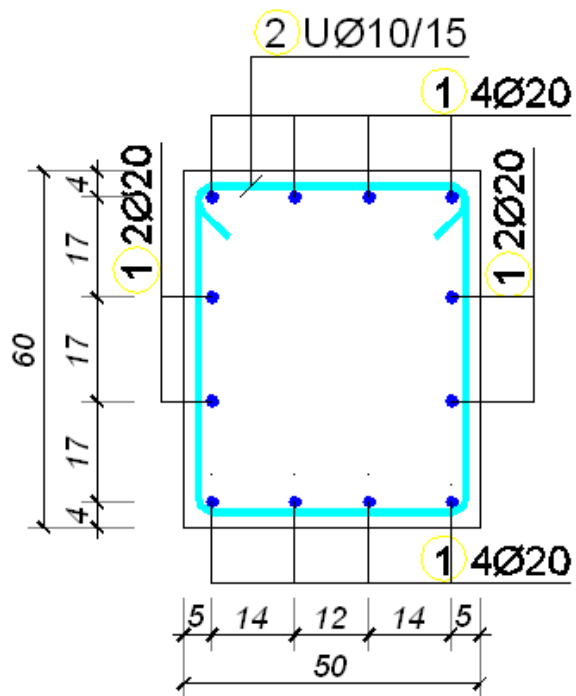

$\theta = 35^\circ$

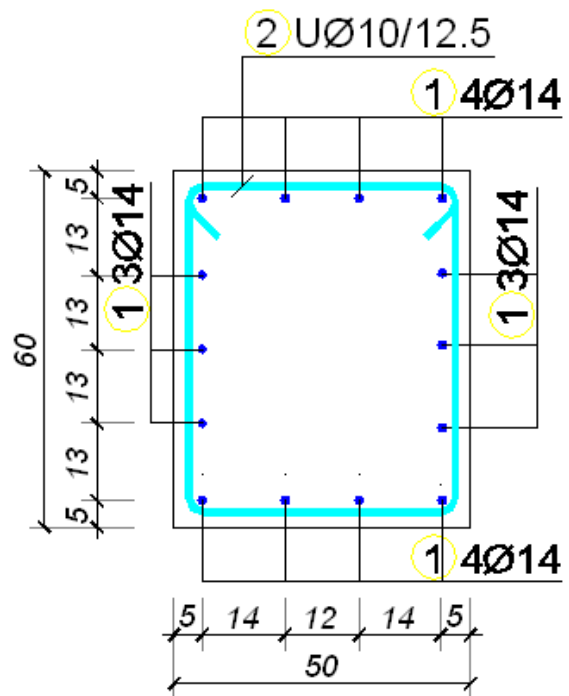

$\theta = 45^\circ$

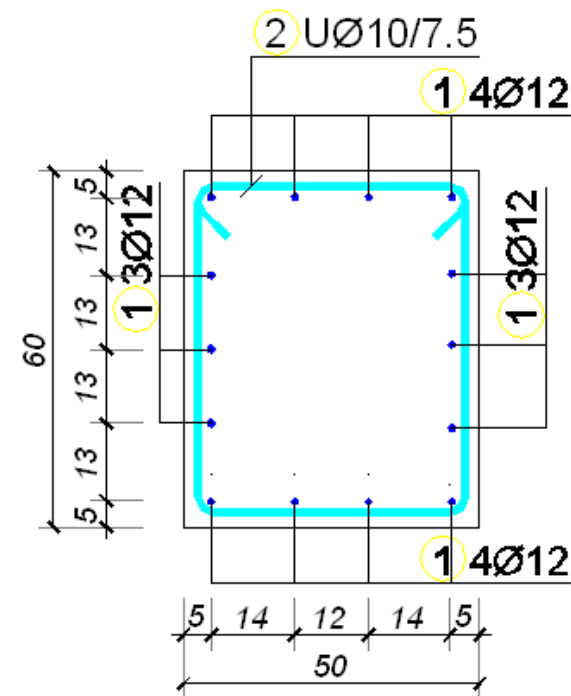

## Zadatak 27 – TORZIJA i TRANSVERZALNE SILE

- Dimenzionisati nosač sistema obostrano uklještene grede, raspona  $L=6.0$  m. Pored sopstvene težine, nosač je opterećen jednako raspodeljenim stalnim ( $\Delta g$ ) i povremenim ( $q$ ) opterećenjem, kao i raspodeljenim momentima torzije  $t_g$  i  $t_q$  usled stalnog, odnosno povremenog opterećenja. Dimenzije poprečnog preseka usvojiti iz uslova da je napon smicanja usled momenata torzije  $\tau_{t,Ed} \leq 1.5 \cdot f_{ctd}$ .

- Zadato opterećenje:

$$\Delta g = 22.5 \text{ kN/m} \quad q = 7.5 \text{ kN/m}$$

$$t_g = 9.0 \text{ kNm/m} \quad t_q = 7.0 \text{ kNm/m}$$

- Karakteristike materijala:

klasa čvrstoće betona: **C 30/37**

$$\rightarrow f_{ck} = 30 \text{ MPa}, f_{cd} = 0.85 \cdot 30 / 1.5 = 17 \text{ MPa}$$

$$f_{ctk,005} = 2.0 \text{ MPa}, f_{ctd} = 0.85 \cdot 2.0 / 1.5 = 1.33 \text{ MPa}$$

kvalitet armature: **B500**  $\rightarrow f_{yk} = 500 \text{ MPa},$

$$f_{yd} = 500 / 1.15 = 434.78 \text{ MPa}$$



# Zadatak 27 – TORZIJA i TRANSVERZALNE SILE

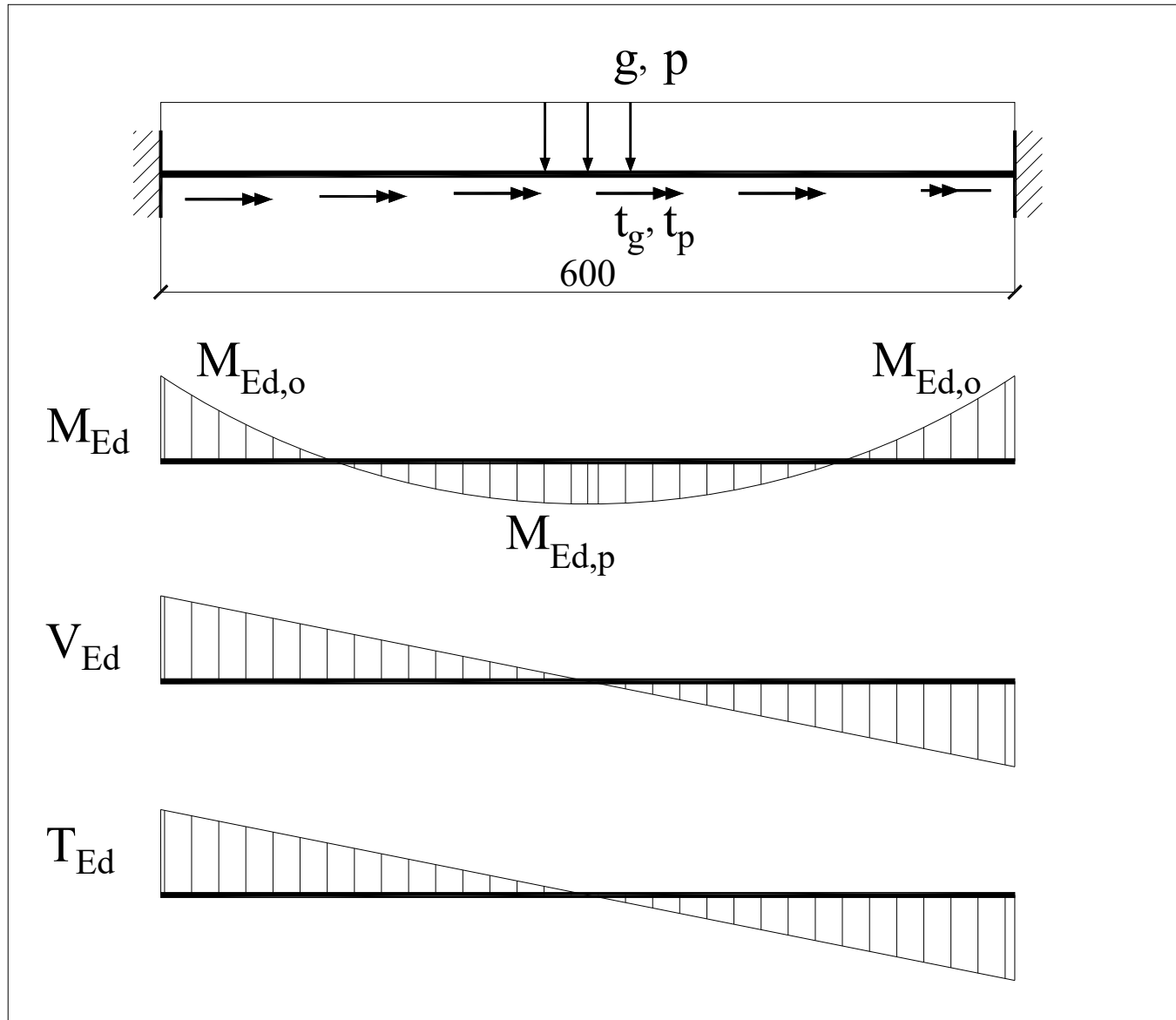



## Zadatak 27 – TORZIJA i TRANSVERZALNE SILE

- Određivanje dimenzija poprečnog preseka, iz uslova  $\tau_{t,Ed} = 1.5 \cdot f_{ctd}$ :

$$t_{Ed} = \gamma_G \cdot t_g + \gamma_Q \cdot t_p = 1.35 \cdot 9 + 1.5 \cdot 7 = 22.65 \text{ kNm/m}$$

$$T_{Ed} = t_{Ed} \cdot L / 2 = 22.65 \cdot 6 / 2 = 67.95 \text{ kNm}$$

$$\tau_{t,Ed} = \frac{T_{Ed}}{2 \cdot A_k \cdot t_{ef}}$$

- Usvaja se položaj težišta podužne armature:  $d_1 = 5.0 \text{ cm}$

$$t_{ef} = \max \left\{ \begin{array}{l} \frac{A}{u} = \frac{b \cdot h}{2 \cdot (b + h)} \\ 2 \cdot d_1 = 2 \cdot 5 = 10.0 \text{ cm} \end{array} \right. \rightarrow$$

pretpostavlja da je drugi uslov merodavan, što kasnije treba dokazati !

$$b_k = b - 2 \cdot \frac{t_{ef}}{2} = b - 2 \cdot \frac{2 \cdot d_1}{2} = b - 2 \cdot d_1$$

$$h_k = h - 2 \cdot \frac{t_{ef}}{2} = h - 2 \cdot \frac{2 \cdot d_1}{2} = h - 2 \cdot d_1$$

$$A_k = h_k \cdot b_k = (b - 2 \cdot d_1) \cdot (h - 2 \cdot d_1)$$

## Zadatak 27 – TORZIJA i TRANSVERZALNE SILE

$$\tau_{t,Ed} = \frac{T_{Ed}}{2 \cdot A_k \cdot t_{ef}} = 1.5 \cdot f_{ctd} = 1.5 \cdot 0.133 = 0.2 \text{ kN/cm}^2$$

$$2 \cdot A_k \cdot t_{ef} = \frac{T_{Ed}}{1.5 \cdot f_{ctd}} = \frac{67.95 \cdot 10^2}{0.2} = 33975 \text{ cm}^3$$

$$2 \cdot A_k \cdot t_{ef} = 2 \cdot (b - 2 \cdot d_1) \cdot (h - 2 \cdot d_1) \cdot d_1$$

$$\Rightarrow h = \frac{33975 \text{ cm}^3}{4 \cdot d_1 \cdot (b - 2 \cdot d_1)} + 2 \cdot d_1$$

|   | b    | h <sub>req</sub> | h <sub>prov</sub> |
|---|------|------------------|-------------------|
| 1 | 35.0 | 77.95            | 80                |
| 2 | 40.0 | 66.63            | 70                |
| 3 | 45.0 | 58.54            | 60                |
| 4 | 50.0 | 52.47            | 55                |
| 5 | 55.0 | 47.75            | 50                |
| 6 | 60.0 | 43.98            | 45                |

⇒ usvojeno b/h = 50 cm/55 cm

## Zadatak 27 – TORZIJA i TRANSVERZALNE SILE

- Karakteristike ekvivalentnog tankozidnog preseka:

$$t_{ef} = \max \left\{ \begin{array}{l} \frac{A}{u} = \frac{b \cdot h}{2 \cdot (b+h)} = \frac{50 \cdot 55}{2 \cdot (50+55)} = \underline{\underline{13.10 \text{ cm}}} \\ 2 \cdot d_1 = 2 \cdot 5 = 10.0 \text{ cm} \end{array} \right. \rightarrow \text{usvojena pretpostavka nije dobra !}$$

- Potrebno je dokazati kolika je vrednost smičućeg napona za usvojene dimenzije preseka:

$$b_k = 50 - 2 \cdot 13.1 / 2 = 36.9 \text{ cm}$$

$$h_k = 55 - 2 \cdot 13.1 / 2 = 41.9 \text{ cm}$$

$$A_k = b_k \cdot h_k = 36.9 \cdot 41.9 = 1546.11 \text{ cm}^2$$

$$u_k = (b_k + h_k) = 2 \cdot (36.9 + 41.9) = 157.6 \text{ cm}^2$$

$$\tau_{t,Ed} = \frac{T_{Ed}}{2 \cdot A_k \cdot t_{ef}} = \frac{67.95 \cdot 10^2}{2 \cdot 1546.11 \cdot 13.1} = 0.1677 \text{ kN/m}^2 < 0.2 \text{ kN/m}^2$$



## Zadatak 27 – TORZIJA i TRANSVERZALNE SILE

- Opterećenje koje deluje na nosač:

- sopstvena težina:  $0.5 \cdot 0.55 \cdot 25 = 6.875 \text{ kN/m}$
- dodatno stalno opterećenje:  $\Delta g = 22.5 \text{ kN/m}$
- ukupno stalno opterećenje:  $g = 29.38 \text{ kN/m}$
- povremeno opterećenje:  $p = 7.5 \text{ kN/m}$

- Granično opterećenje i uticaji:

$$q_{Ed} = \gamma_G \cdot g + \gamma_Q \cdot p = 1.35 \cdot 29.38 + 1.5 \cdot 7.5 = 50.91 \text{ kNm/m}$$

$$M_{Ed,o} = \frac{50.91 \cdot 6^2}{12} = 152.73 \text{ kNm}$$

$$M_{Ed,p} = \frac{50.91 \cdot 6^2}{24} = 76.37 \text{ kNm}$$

$$V_{Ed} = \frac{50.91 \cdot 6}{2} = 152.73 \text{ kN}$$



## Zadatak 27 – TORZIJA i TRANSVERZALNE SILE

- Dimenzionisanje prema momentima savijanja:

- Oslonac:

$$A_{s2} = 7.474 \cdot \frac{50 \cdot 50}{100} \cdot \frac{1.7}{43.478} = 7.31 \text{ cm}^2 \Rightarrow \text{usvojeno: } \underline{4\emptyset 16 (8.04 \text{ cm}^2)}$$
$$\Rightarrow \rho_1 = 8.04 / (50 \cdot 50) = 0.00322$$

- Polje:

$$l_o = 0.7 \cdot L = 0.7 \cdot 6.0 = 4.2 \text{ m} \rightarrow b_{\text{eff}} = b + 0.2 \cdot l_o = 50 + 0.2 \cdot 420 = 134 \text{ cm}$$

$$A_{s1} = 1.35 \cdot \frac{134 \cdot 50}{100} \cdot \frac{1.7}{43.478} = 3.54 \text{ cm}^2$$

$$A_{s,\text{min}} = \max \left\{ \begin{array}{l} 0.0013 \cdot b \cdot d = 0.0013 \cdot 50 \cdot 50 = 3.25 \text{ cm}^2 \\ 0.26 \cdot \frac{f_{\text{ctm}}}{f_{\text{yd}}} \cdot b \cdot d = 0.26 \cdot \frac{2.9}{500} \cdot 50 \cdot 50 = 3.77 \text{ cm}^2 \end{array} \right.$$

$$\Rightarrow \text{usvojeno: } \underline{2\emptyset 16 (4.02 \text{ cm}^2)}$$



## Zadatak 27 – TORZIJA i TRANSVERZALNE SILE

- Određivanje nosivosti AB preseka na smicanje bez poprečne armature:

$$C_{Rd,c} = 0.12 \quad , \quad k = 1 + \sqrt{\frac{200}{500}} = 1.632 \quad V_{Rd,c} = \left[ C_{Rd,c} \cdot k \cdot (100 \rho_i f_{ck})^{1/3} + k_1 \cdot \sigma_{cp} \right] \cdot b_w \cdot d$$

$$V_{c,Rd} = \max \left\{ \begin{array}{l} (0.12 \cdot 1.632 \cdot \sqrt[3]{100 \cdot 0.0032 \cdot 30}) \cdot 50 \cdot 50 \cdot 10^{-1} = \underline{\underline{104.08 \text{ kN}}} \\ (0.035 \cdot 1.632^{3/2} \cdot 30^{1/2}) \cdot 50 \cdot 50 \cdot 10^{-1} = 99.92 \text{ kN} \end{array} \right.$$

- Određivanje nosivosti AB preseka na torziju bez učešća armature:

$$T_{c,Rd} = f_{ctd} \cdot 2 \cdot A_k \cdot t_{ef} = 0.133 \cdot 2 \cdot 1546.11 \cdot 13.1 \cdot 10^{-2} = 53.88 \text{ kNm}$$

- Kontrola nosivosti preseka na interakciju smicanja i torzije:

$$\frac{T_{Ed}}{T_{c,Rd}} + \frac{V_{Ed}}{V_{c,Rd}} = \frac{67.95}{53.88} + \frac{152.73}{104.08} = 2.729 > 1.0 \rightarrow \text{potrebno je računski odrediti površinu poprečne i podužne armature !}$$

## Zadatak 27 – TORZIJA i TRANSVERZALNE SILE

- Maksimalna sila smicanja koju presek može da prihvati:

$$\alpha_{cw} = 1.0, \quad v = 0.6 \cdot (1 - 30/250) = 0.528$$

$$z = 0.9 \cdot d = 45 \text{ cm}, \quad \theta = 45^\circ, \quad \alpha = 90^\circ$$

$$V_{Rd,max} = 1.0 \cdot 0.528 \cdot 1.7 \cdot 50 \cdot 45 \cdot (\text{ctg}45^\circ + \text{ctg}90^\circ) \cdot \sin^2 45^\circ = 1009.8 \text{ kN}$$

- Maksimalni moment torzije koji presek može da prihvati:

$$T_{Rd,max} = 2 \cdot 1546.11 \cdot 1.0 \cdot 0.528 \cdot 1.7 \cdot 13.1 \cdot \sin 45^\circ \cdot \cos 45^\circ \cdot 10^{-2} = 181.8 \text{ kNm}$$

- Kontrola maksimalne nosivosti preseka na interakciju smicanja i torzije:

$$\frac{T_{Ed}}{T_{Rd,max}} + \frac{V_{Ed}}{V_{Rd,max}} = \frac{67.95}{181.8} + \frac{152.73}{1009.8} = 0.525 < 1.0$$



# Zadatak 27 – TORZIJA i TRANSVERZALNE SILE

- Određivanje potrebne površine poprečne armature - uzengija:

- Potrebne uzengije za prihvatanje sile smicanja:  $m = 4$

$$\frac{A_{sw,V}}{s_{w,V}} = \frac{4 \cdot a_{sw,V}^{(1)}}{s_{w,V}} = \frac{152.73}{43.5 \cdot 45 \cdot \text{ctg}45^\circ} = 0.07806$$

$$\rightarrow a_{sw,V}^{(1)} = 0.07806 / 4 \cdot s_{w,V} = 0.0195 \cdot s_{w,V}$$

- Minimalna propisana površina poprečne armature za prihvatanje sile smicanja:

$$\rho_{w,\min} = 0.08 \sqrt{f_{ck}} / f_{yk} = 0.08 \sqrt{30} / 500 = 0.000876$$

$$\left( \frac{a_{sw,V}^{(1)}}{s_{w,V}} \right)_{\min} = \frac{1}{m_V} \cdot \rho_{w,\min} \cdot b \cdot \sin \alpha = \frac{1}{4} \cdot 0.000876 \cdot 50 \cdot \sin 90^\circ = 0.01095 < \frac{a_{sw,V}^{(1)}}{s_{w,V}}$$

- Potrebne uzengije za prihvatanje momenata torzije:

$$\frac{a_{sw}}{s_w} = \frac{T_{Ed}}{2 \cdot A_k \cdot f_{ywd} \cdot \text{ctg} \theta}$$

$$\frac{A_{sw,T}}{s_{w,T}} = \frac{a_{sw,T}^{(1)}}{s_{w,T}} = \frac{67.95 \cdot 10^2}{2 \cdot 1546.11 \cdot 43.478} \cdot \text{tg}45^\circ = 0.0505$$

$$\rightarrow a_{sw,T}^{(1)} = 0.0505 \cdot s_{w,T}$$





## Zadatak 27 – TORZIJA i TRANSVERZALNE SILE

- Minimalna propisana površina poprečne armature za prihvatanje torzije:

$$\left( \frac{a_{sw,T}^{(1)}}{s_{w,T}} \right)_{\min} = \frac{1}{m_T} \cdot \rho_{w,\min} \cdot b \cdot \sin \alpha = \frac{1}{1} \cdot 0.000876 \cdot 50 \cdot \sin 90^\circ = 0.0438 < \frac{a_{sw,T}^{(1)}}{s_{w,T}}$$

- Spoljašnje uzengije:

$$a_{sw}^{(1)} = a_{sw,V}^{(1)} + a_{sw,T}^{(1)} = 0.0195 \cdot s_{w,V} + 0.0505 \cdot s_{w,T} = 0.070 \cdot s_w, \quad (s_{w,V} = s_{w,T})$$

$$U\emptyset 10 \Rightarrow s_w = \frac{0.785}{0.070} = 11.21 \text{ cm} \quad \Rightarrow \text{usvojeno: } \underline{U\emptyset 10 / 10 \text{ cm}}$$

- Unutrašnje uzengije:

$$a_{sw,V}^{(1)} = 0.0195 \cdot s_{w,V}$$

$$U\emptyset 8 \Rightarrow s_w = \frac{0.503}{0.0195} = 25.79 \text{ cm} \quad \Rightarrow \text{usvojeno: } \underline{U\emptyset 8 / 20 \text{ cm}}$$



# Zadatak 27 – TORZIJA i TRANSVERZALNE SILE

- Podužna armatura za prihvatanje torzije:

$$A_{sl} = \frac{67.95 \cdot 10^2}{2 \cdot 1546.11 \cdot 43.478} \cdot 157.6 \cdot \text{ctg}45^\circ = 7.97 \text{ cm}^2$$

⇒ usvojeno : 14Ø10 (10.99 cm<sup>2</sup>)

- Dodatna zategnuta armatura na mestu oslonca:

$$\Delta A_s = 0.0 \text{ cm}^2 \text{ ("špic" momenata)}$$

za  $T_{Ed}$ :  $4\text{Ø}10 = 3.14 \text{ cm}^2$

za  $M_{Ed}$ :  $= 7.31 \text{ cm}^2$

---

ukupno:  $= 10.45 \text{ cm}^2$

usvojeno:  $7\text{Ø}14 (10.78 \text{ cm}^2)$

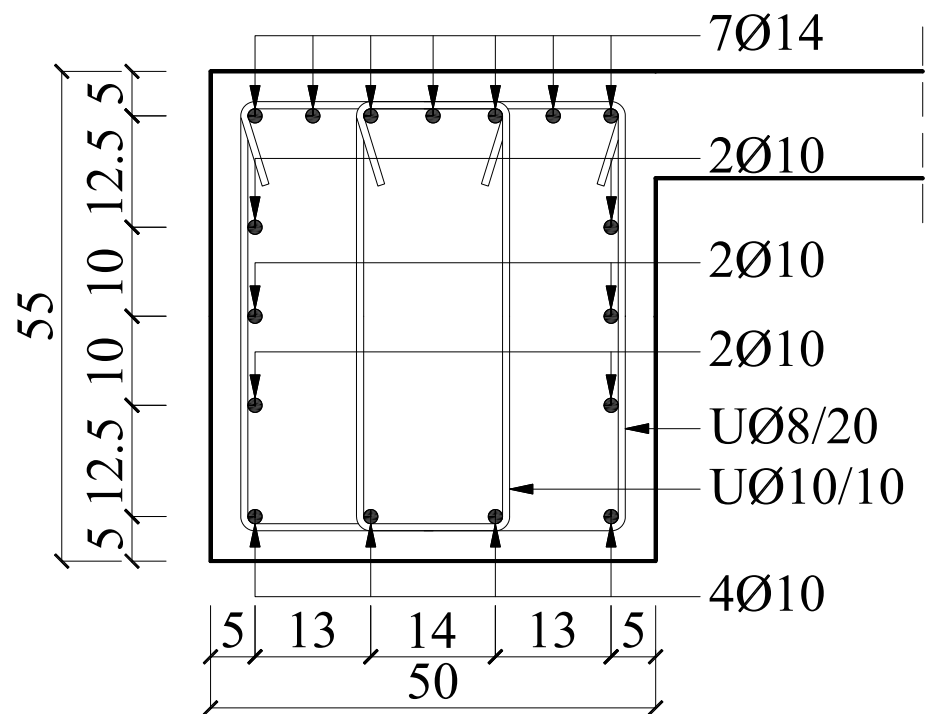

# Zadatak 27a – TORZIJA I TRANSVERZALNE SILE

- Određivanje dimenzija poprečnog preseka, iz uslova  $\tau_{t,Ed} = 1.5 \cdot f_{ctd}$ :

$$t_{Ed} = \gamma_G \cdot t_g + \gamma_Q \cdot t_p = 1.35 \cdot 9 + 1.5 \cdot 7 = 22.65 \text{ kNm/m}$$

$$T_{Ed} = t_{Ed} \cdot L / 2 = 22.65 \cdot 6 / 2 = 67.95 \text{ kNm}$$

- Usvaja se položaj težišta podužne armature:  $d_1 = 5.0 \text{ cm}$

$$t_{ef} = \max \left\{ \begin{array}{l} \frac{A}{u} = \frac{b \cdot h}{2 \cdot (b + h)} = \frac{b}{2 \cdot (1 + b/h)} \rightarrow \text{pretpostavlja da je prvi uslov} \\ 2 \cdot d_1 = 2 \cdot 5 = 10.0 \text{ cm} \end{array} \right. \text{merodavan, što kasnije treba dokazati !}$$

$$b_k = b - 2 \cdot \frac{t_{ef}}{2} = b - \frac{b \cdot h}{2 \cdot (b + h)} = b \cdot \left( 1 - \frac{h}{2 \cdot (1 + h/b)} \right)$$

$$h_k = h - 2 \cdot \frac{t_{ef}}{2} = h - \frac{b \cdot h}{2 \cdot (b + h)} = h \cdot \left( 1 - \frac{b}{2 \cdot (1 + b/h)} \right)$$

$$A_k = h_k \cdot b_k = h \cdot b \cdot \left( 1 - \frac{b}{2 \cdot (1 + b/h)} \right) \cdot \left( 1 - \frac{h}{2 \cdot (1 + h/b)} \right)$$



## Zadatak 27a – TORZIJA i TRANSVERZALNE SILE

$$\tau_{t,Ed} = \frac{T_{Ed}}{2 \cdot A_k \cdot t_{ef}} = 1.5 \cdot f_{ctd} = 1.5 \cdot 0.133 = 0.2 \text{ kN/cm}^2$$

$$2 \cdot A_k \cdot t_{ef} = \frac{T_{Ed}}{1.5 \cdot f_{ctd}} = \frac{43.2 \cdot 10^2}{0.2} = 21150 \text{ cm}^3$$

$$2 \cdot A_k \cdot t_{ef} = \frac{b^2 \cdot h}{(1 + b/h)} \cdot \left(1 - \frac{b}{2 \cdot (1 + b/h)}\right) \cdot \left(1 - \frac{h}{2 \cdot (1 + h/b)}\right) = 21150 \text{ cm}^3$$

# NAGRADNI ZADATAK



Dimenzionisati stub POS S1 visine  $H=5,0$  m, pravougaonog poprečnog preseka ( $b/d=60/60$  cm), koji je opterećen datim silama usled stalnog ( $G$ ), povremenog ( $Q$ ) i opterećenja vetrom ( $\pm w$ ).  $Q$  i  $w$  mogu delovati nezavisno.

C35/45  
B500 B  
 $b/h=60/60$  cm

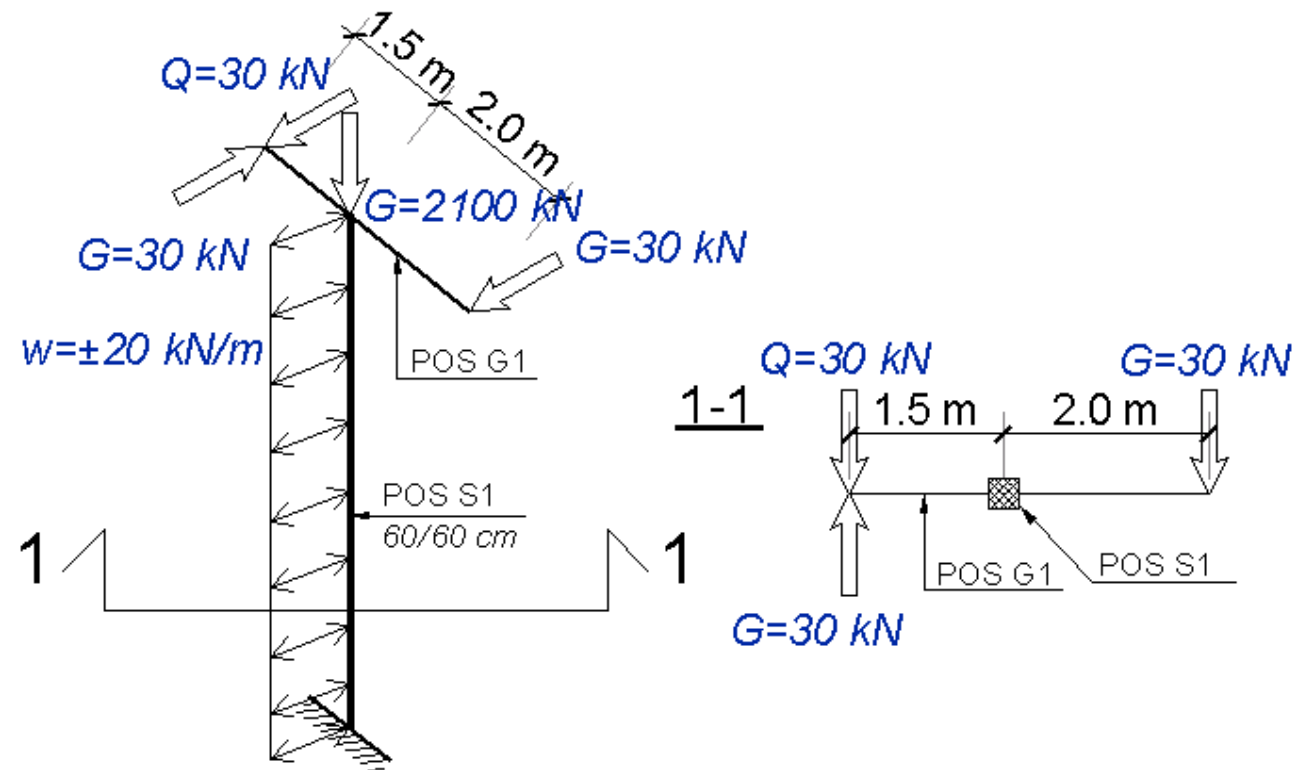

## Zadatak 28 – TORZIJA i TRANSVERZALNE SILE

- Za nosač POS 1 prikazan na skici nacrtati dijagrame presečnih sila usled prikazanih sila  $G = 150 \text{ kN}$ , a zatim izvršiti osiguranje od glavnih napona zatezanja na pojedinim delovima nosača.
- Nosač nije potrebno dimenzionisati prema momentima savijanja.
- Karakteristike preseka:  $b = 45 \text{ cm}$ ,  $h = 60 \text{ cm}$
- Karakteristike materijala: **C 30/37**, **B500**

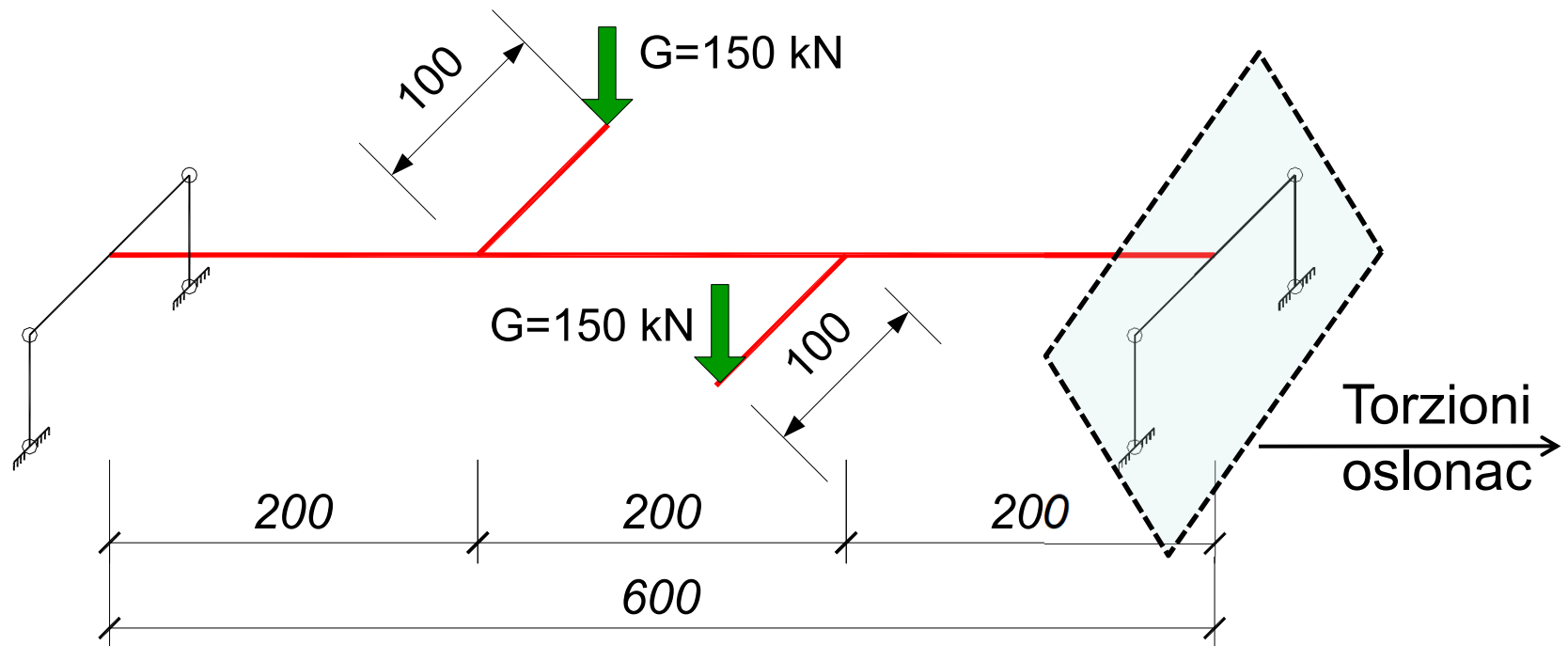

# Zadatak 28 – TORZIJA i TRANSVERZALNE SILE

Torzioni oslonac:

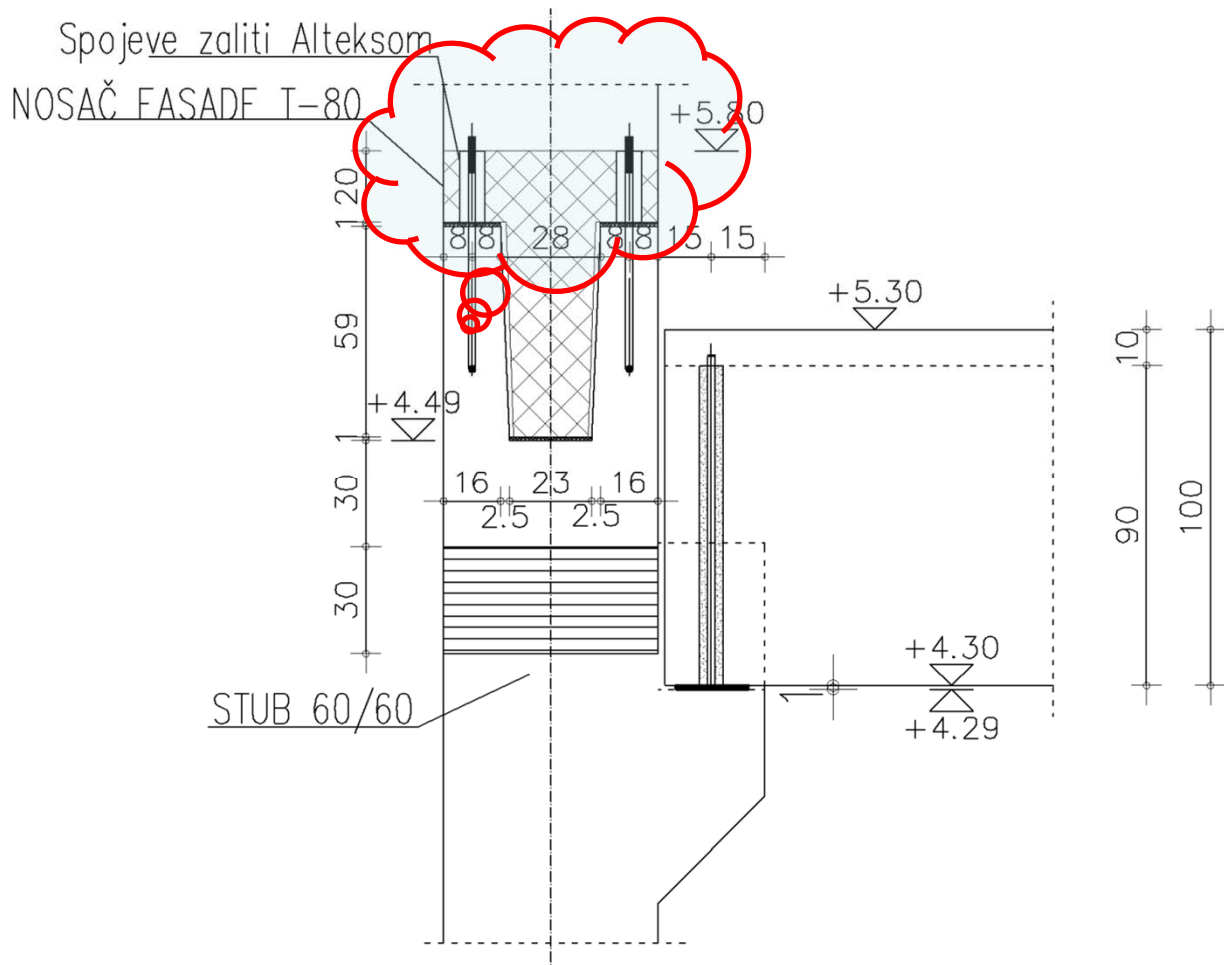

# Zadatak 28 – TORZIJA i TRANSVERZALNE SILE

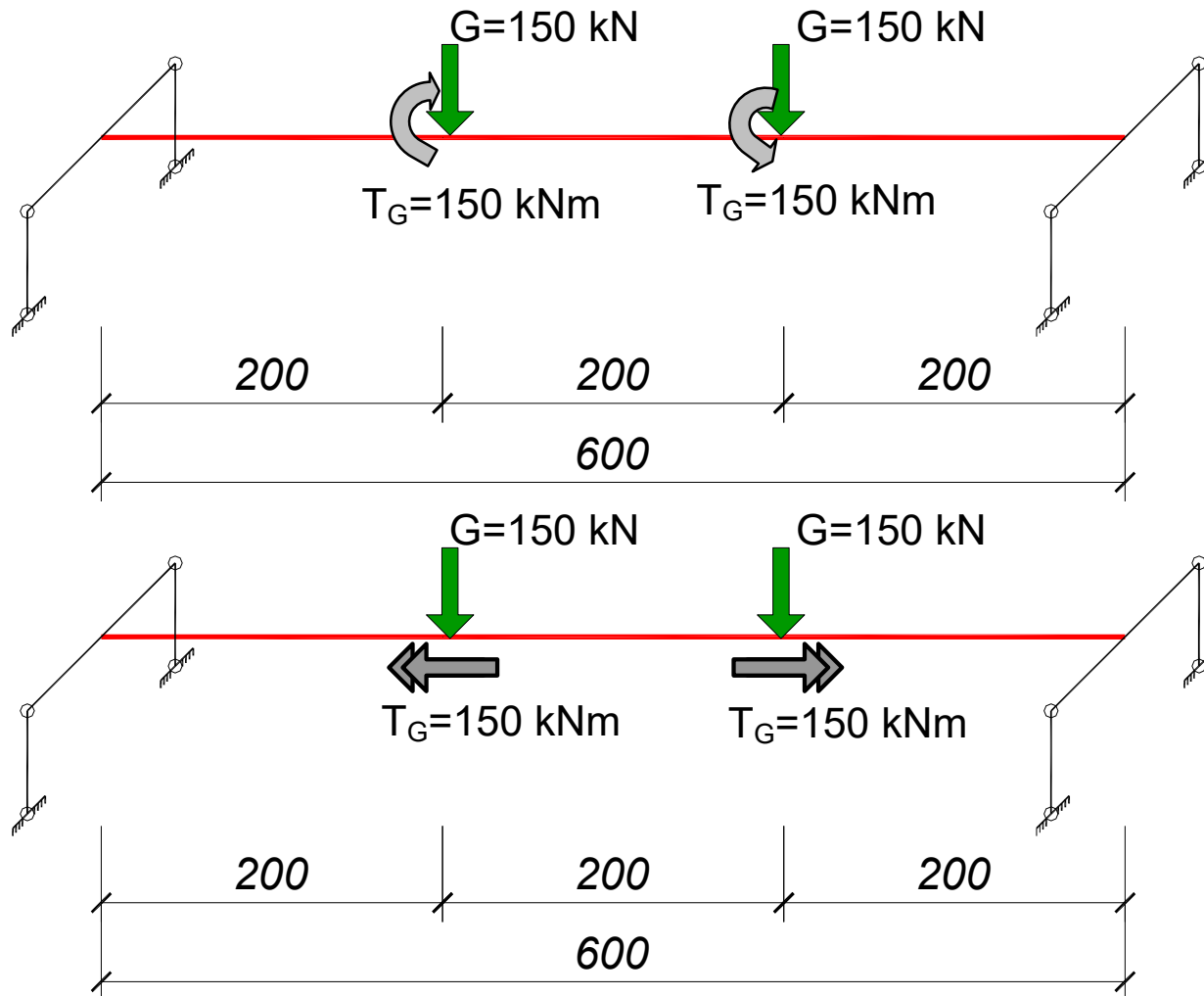



# Zadatak 28 – TORZIJA i TRANSVERZALNE SILE

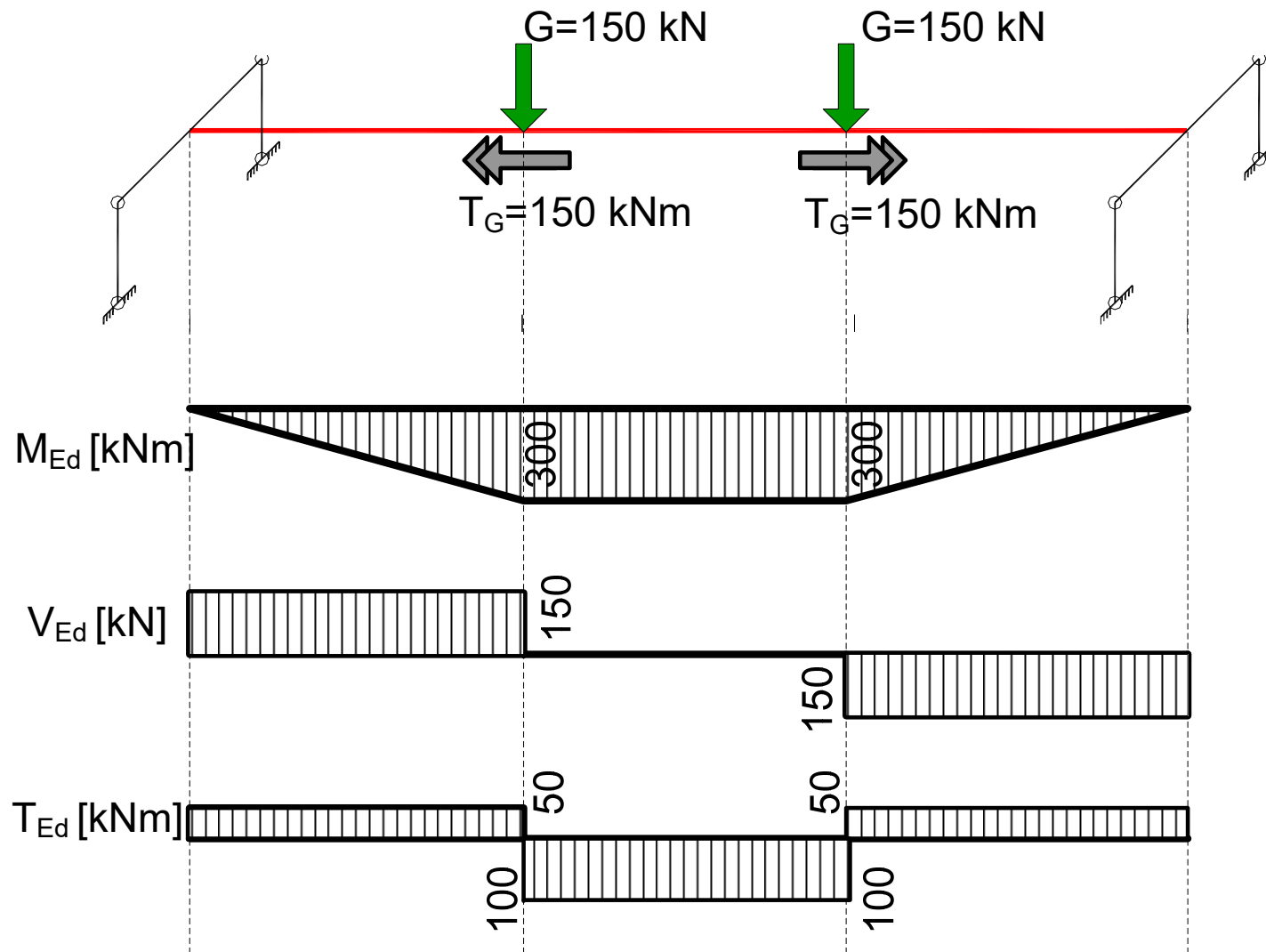

# Zadatak 28 – TORZIJA i TRANSVERZALNE SILE

- Analiziraju se krajnje trećine nosača

- Proračunske vrednosti uticaja:

$$V_{Ed} = \gamma_G \cdot V_g = 1.35 \cdot 150 = 202.5 \text{ kN}$$

$$T_{Ed} = \gamma_G \cdot T_g = 1.35 \cdot 50 = 67.5 \text{ kNm}$$

- Karakteristike ekvivalentnog tankozidnog preseka:

$$t_{ef} = \max \left\{ \begin{array}{l} \frac{A}{u} = \frac{b \cdot h}{2 \cdot (b + h)} = \frac{45 \cdot 60}{2 \cdot (45 + 60)} = \underline{\underline{12.86 \text{ cm}}} A_k \\ 2 \cdot d_1 = 2 \cdot 5 = 10.0 \text{ cm} \end{array} \right.$$

$$b_k = b - 2 \cdot t_{ef} / 2 = 50 - 2 \cdot 12.86 / 2 = 32.14 \text{ cm}$$

$$h_k = h - 2 \cdot t_{ef} / 2 = 60 - 2 \cdot 12.86 / 2 = 47.14 \text{ cm}$$

$$A_k = b_k \cdot h_k = 32.14 \cdot 47.14 = 1515.08 \text{ cm}^2$$

$$u_k = 2 \cdot (b_k + h_k) = 2 \cdot (32.14 + 47.14) = 158.56 \text{ cm}$$

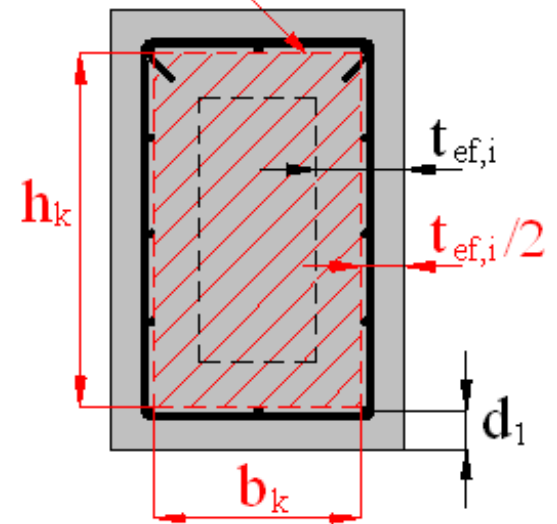

# Zadatak 28 – TORZIJA i TRANSVERZALNE SILE

1. Određivanje nosivosti AB preseka na smicanje bez poprečne armature:

- Pretpostavlja se da je presek armiran minimalnim procentom podužne armature za savijanje\*:  $d = h - d_1 = 60 - 5 = 55 \text{ cm}$

$$A_{s,\min} = \max \left\{ \begin{array}{l} 0.0013 \cdot b \cdot d = 0.0013 \cdot 45 \cdot 55 = 3.22 \text{ cm}^2 \\ 0.26 \cdot \frac{f_{ctm}}{f_{yd}} \cdot b \cdot d = 0.26 \cdot \frac{2.9}{500} \cdot 45 \cdot 55 = 3.73 \text{ cm}^2 \end{array} \right.$$

$$\Rightarrow \text{usvojeno: } \underline{2\text{Ø}16 (4.02 \text{ cm}^2)} \Rightarrow \rho_1 = 4.02 / (45 \cdot 55) = 0.0016$$

$$C_{Rd,c} = 0.12, \quad k = 1 + \sqrt{\frac{200}{55 \cdot 10}} = 1.603$$

$$V_{c,Rd} = \max \left\{ \begin{array}{l} \left( 0.12 \cdot 1.603 \cdot \sqrt[3]{100 \cdot 0.0016 \cdot 30} \right) \cdot 45 \cdot 55 \cdot 10^{-1} = 80.31 \text{ kN} \\ \left( 0.035 \cdot 1.603^{3/2} \cdot 30^{1/2} \right) \cdot 45 \cdot 55 \cdot 10^{-1} = \underline{\underline{96.30 \text{ kN}}} \end{array} \right.$$



## Zadatak 28 – TORZIJA i TRANSVERZALNE SILE

2. Određivanje nosivosti AB preseka na torziju bez učešća armature:

$$T_{c,Rd} = f_{ctd} \cdot 2 \cdot A_k \cdot t_{ef} = 0.133 \cdot 2 \cdot 1515.08 \cdot 12.86 \cdot 10^{-2} = 51.83 \text{ kNm}$$

3. Kontrola nosivosti preseka na interakciju smicanja i torzije:

$$\frac{T_{Ed}}{T_{c,Rd}} + \frac{V_{Ed}}{V_{c,Rd}} = \frac{67.5}{51.83} + \frac{202.5}{96.3} = 3.402 > 1.0 \rightarrow \text{potrebno je računski odrediti površinu poprečne i podužne armature !}$$

4. Maksimalna sila smicanja koju presek može da prihvati:

$$V_{Rd,max} = \frac{\alpha_{cw} \cdot b_w \cdot z \cdot v_1 \cdot f_{cd}}{ctg\theta + tg\theta} = \frac{1.0 \cdot 45 \cdot 0.9 \cdot 55 \cdot 0.528 \cdot 1.7}{ctg45 + tg45} = 999.7 \text{ kN}$$

$$\alpha_{cw} = 1.0 \quad , \quad v = 0.6 \cdot (1 - 30 / 250) = 0.528$$

$$z = 0.9 \cdot d = 49.5 \text{ cm}, \quad \theta = 45^\circ, \quad \alpha = 90^\circ$$

5. Maksimalni moment torzije koji presek može da prihvati:

$$T_{Rd,max} = 2 \cdot A_k \cdot \alpha_{cw} \cdot v \cdot f_{cd} \cdot t_{ef,i} \cdot \sin\theta \cdot \cos\theta$$

$$T_{Rd,max} = 2 \cdot 1515.31 \cdot 1.0 \cdot 0.528 \cdot 1.7 \cdot 12.86 \cdot \sin 45^\circ \cdot \cos 45^\circ \cdot 10^{-2} = 174.91 \text{ kNm}$$



## Zadatak 28 – TORZIJA i TRANSVERZALNE SILE

6. Kontrola maksimalne nosivosti preseka na interakciju smicanja i torzije:

$$\frac{T_{Ed}}{T_{Rd,max}} + \frac{V_{Ed}}{V_{Rd,max}} = \frac{67.5}{174.91} + \frac{202.5}{999.70} = 0.588 < 1.0$$

7. Određivanje potrebne površine poprečne armature - uzengija:

- Potrebne uzengije za prihvatanje sile smicanja:  $m = 4$

$$V_{Rd,s} = \frac{A_{sw,V}}{s_V} \cdot z \cdot f_{ywd} \cdot ctg\theta = V_{Ed} = \frac{m \cdot a_{sw,V}}{s_V} \cdot z \cdot f_{ywd} \cdot ctg\theta$$

$$\frac{4 \cdot a_{sw,V}^{(1)}}{s_V} = \frac{202.5}{49.5 \cdot 43.5 \cdot ctg45^\circ} = 0.0941$$

$$\frac{a_{sw,V}^{(1)}}{s_V} = \frac{0.0941}{4} = 0.0235$$



$$a_{sw,V}^{(1)} = 0.0941 / 4 \cdot s_V = 0.0235 \cdot s_V$$

# Zadatak 28 – TORZIJA i TRANSVERZALNE SILE

- Potrebne uzengije za prihvatanje momenata torzije:

$$\frac{a_{sw}}{s_T} = \frac{T_{Ed}}{2 \cdot A_k \cdot f_{ywd} \cdot ctg\theta}$$

$$\frac{a_{sw,T}^{(1)}}{s_T} = \frac{67.5 \cdot 10^2}{2 \cdot 1515.31 \cdot 43.5} \cdot tg45^\circ = 0.0512$$



$$a_{sw,T}^{(1)} = 0.0512 \cdot s_T$$

8. Kontrola minimalne poprečne armature :  $\rho_{w,min} = 0.08\sqrt{30} / 500 = 0.000876$

- Za silu smicanja:

$$\left( \frac{a_{sw,V}^{(1)}}{s_V} \right)_{min} = \frac{1}{m_V} \cdot \rho_{w,min} \cdot b \cdot \sin \alpha = \frac{1}{4} \cdot 0.000876 \cdot 45 \cdot \sin 90^\circ = 0.0099 < 0.0235 = \frac{a_{sw,V}^{(1)}}{s_V}$$

- Za moment torzije:

$$\left( \frac{a_{sw,T}^{(1)}}{s_{w,T}} \right)_{min} = \frac{1}{m_T} \cdot \rho_{w,min} \cdot b \cdot \sin \alpha = \frac{1}{1} \cdot 0.000876 \cdot 45 \cdot \sin 90^\circ = 0.0394 < 0.0512 = \frac{a_{sw,T}^{(1)}}{s_T}$$



# Zadatak 28 – TORZIJA i TRANSVERZALNE SILE

## 9. Usvajanje poprečne armature

- Spoljašnje uzengije:

$$a_{sw}^{(1)} = a_{sw,V}^{(1)} + a_{sw,T}^{(1)} = 0.0235 \cdot s_V + 0.0512 \cdot s_T = 0.0747 \cdot s, \quad (s_V = s_T)$$
$$U\emptyset 10 \Rightarrow s = \frac{0.785}{0.0747} = 10.51 \text{ cm} \Rightarrow \text{usvojeno : } \underline{U\emptyset 10 / 10 \text{ cm}}$$

- Unutrašnje uzengije:

$$a_{sw,V}^{(1)} = 0.0235 \cdot s_V$$
$$U\emptyset 8 \Rightarrow s = \frac{0.503}{0.0235} = 21.40 \text{ cm} \Rightarrow \text{usvojeno : } \underline{U\emptyset 8 / 20 \text{ cm}}$$

10. Podužna armatura za prihvatanje torzije:

$$A_{sl} = \frac{67.5 \cdot 10^2}{2 \cdot 1515.31 \cdot 43.478} \cdot 158.56 \cdot \text{ctg}45^\circ = 8.12 \text{ cm}^2$$

11. Dodatna zategnuta armatura na krajnjem osloncu:

$$\Delta A_s = \frac{202.5}{2 \cdot 43.478} \cdot (\text{ctg}45^\circ - \text{ctg}90^\circ) = 2.33 \text{ cm}^2$$

