

Pismeni ispit, 16.09.2015., grupe A+B

1

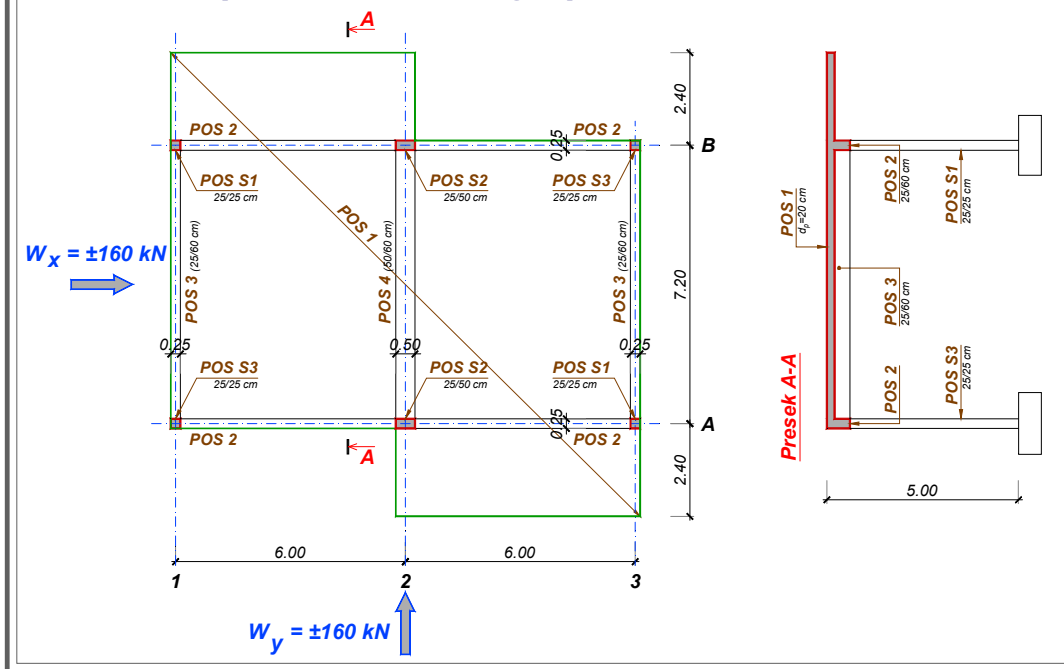

$$g = 0.20 \times 25 = 5.0 \text{ kN/m}^2$$

$$p = 10 \text{ kN/m}^2$$

konzolna ploča (deo "A")

$$R_g = 5.0 \times 2.4 = 12.0 \text{ kN/m}$$

$$R_p = 10.0 \times 2.4 = 24.0 \text{ kN/m}$$

$$q_u = 1.6 \times 5.0 + 1.8 \times 10.0 = 26.0 \text{ kN/m}^2$$

$$M_u = 26.0 \times 2.4^2 / 2 = 74.88 \text{ kNm/m}$$

krstasta ploča (deo "B")

Kako se povremeno opterećenje može naći u proizvoljnom položaju na konstrukciji, potrebno ga je razdvojiti na simetrični deo $p/2$ (deluje po čitavoj površini ploče) i antisimetrični deo $\pm p/2$ (razlikuje se u zavisnosti od razmatranog uticaja).

2

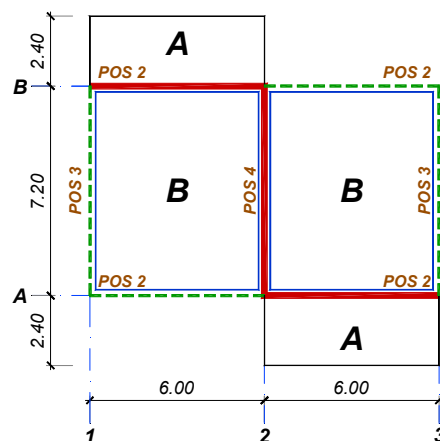

Simetrični deo (g, p/2)

3

$$g = 0.20 \times 25 = 5.0 \text{ kN/m}^2$$

$$p = 10 \text{ kN/m}^2$$

$$L_y/L_x = 7.2/6.0 = 1.2$$

$$G = 5.0 \times 6.0 \times 7.2 = 216 \text{ kN} = P/2$$

$$Q_{u1} = 1.6 \times G + 1.8 \times P/2 = 734.4 \text{ kN}$$

$$M_{xu1} = 0.032 \times 734.4 = 23.5 \text{ kNm/m}$$

$$M_{yu1} = 0.023 \times 734.4 = 16.9 \text{ kNm/m}$$

$$-X_{u1} = 0.071 \times 734.4 = 52.1 \text{ kNm/m}$$

$$-Y_{u1} = 0.062 \times 734.4 = 45.5 \text{ kNm/m}$$

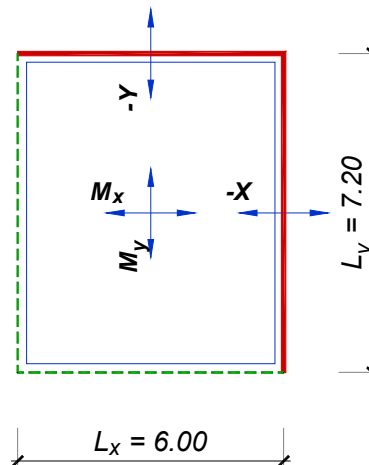

Antimetrični deo ($\pm p/2$)

4

$$P/2 = 5.0 \times 6.0 \times 7.2 = 216 \text{ kN}$$

$$Q_{u2} = \pm 1.8 \times P/2 = \pm 1.8 \times 216 = \pm 388.8 \text{ kN}$$

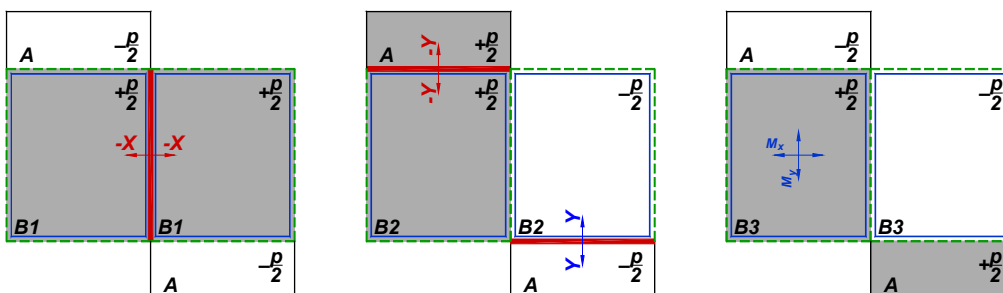

Šeme povremenog opterećenja koje daju najveće momente nad osloncima i u poljima su prikazane na skici. Pri tome se srednja šema (maksimalni momenti $-Y$) neće ni razmatrati, s obzirom da se na spoju konzolne i krstaste ploče uvek usvaja moment sa konzole.

Maksimalni oslonački moment -X

5

$$-X_{u2} = k^{B1} \times Q_{u2} = 0.082 \times Q_{u2}$$

$$-X_{u2} = 0.082 \times 388.8 = 31.9 \text{ kNm/m}$$

$$-X_u = (-X)_{u1} + (-X)_{u2} = 52.1 + 31.9 = 84.0 \text{ kNm/m}$$

$$\text{pretp. } a_{1x} = 3.0 \text{ cm}$$

$$h_x = d - a_1 = 20 - 3 = 17 \text{ cm}$$

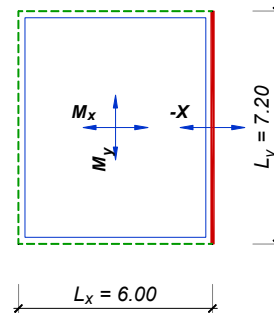

$$k = \frac{17}{\sqrt{\frac{84.0}{2.05}}} = 2.655 \Rightarrow \begin{aligned} \varepsilon_b / \varepsilon_a &= 2.615 / 10\text{‰} \\ \bar{\mu} &= 15.444\% \\ \zeta &= 0.918 \end{aligned}$$

$$A_a = 15.444 \times 17 \times \frac{2.05}{40} = 13.46 \frac{\text{cm}^2}{\text{m}} \Rightarrow \text{usv.: R}\text{\O}16/15 \text{ (13.40 cm}^2/\text{m)}$$

$$A_{ap} = 0.2 \times 13.46 = 2.69 \frac{\text{cm}^2}{\text{m}} \Rightarrow \text{usv.: R}\text{\O}10/25 \text{ (3.14 cm}^2/\text{m)}$$

Maksimalni oslonački moment -Y

6

$$-Y_u = 74.88 \text{ kNm/m (moment sa konzolne ploče)}$$

$$a_{1y} = 2.0 + 1.6 + 1.6/2 = 4.4 \text{ cm}$$

$$h_y = 20 - 4.4 = 15.6 \text{ cm}$$

$$k = \frac{15.6}{\sqrt{\frac{74.88}{2.05}}} = 2.581 \Rightarrow \begin{aligned} \varepsilon_b / \varepsilon_a &= 2.763 / 10\text{‰} \\ \bar{\mu} &= 16.427\% \\ \zeta &= 0.914 \end{aligned}$$

$$A_a = 16.427 \times 15.6 \times \frac{2.05}{40} = 13.13 \frac{\text{cm}^2}{\text{m}} \Rightarrow \text{usv.: R}\text{\O}16/15 \text{ (13.40 cm}^2/\text{m)}$$

$$A_{ap} = 0.2 \times 13.13 = 2.63 \frac{\text{cm}^2}{\text{m}} \Rightarrow \text{usv.: R}\text{\O}10/25 \text{ (3.14 cm}^2/\text{m)}$$

Maksimalni momenti u polju M_x , M_y

7

$$M_{xu2} = k^{B3} \times Q_{u2} = 0.049 \times Q_{u2}$$

$$M_{xu2} = 0.049 \times 388.8 = 19.1 \text{ kNm/m}$$

$$M_{xu} = M_{xu1} + M_{xu2} = 23.5 + 19.1 = 42.6 \text{ kNm/m}$$

$$M_{yu2} = k^{B3} \times Q_{u2} = 0.038 \times Q_{u2}$$

$$M_{yu2} = 0.038 \times 388.8 = 14.8 \text{ kNm/m}$$

$$M_{yu} = M_{yu1} + M_{yu2} = 16.9 + 14.8 = 31.7 \text{ kNm/m}$$

$$a_{1x} = 2.0 + 1.2/2 = 2.6 \text{ cm}$$

$$h_x = 20 - 2.6 = 17.4 \text{ cm}$$

$$A_{ax} \approx \frac{42.6 \times 10^2}{0.9 \times 17.4 \times 40} = 6.79 \frac{\text{cm}^2}{\text{m}} \Rightarrow \text{usv.: R}\mathbf{\text{Ø12/15}} (7.54 \text{ cm}^2/\text{m})$$

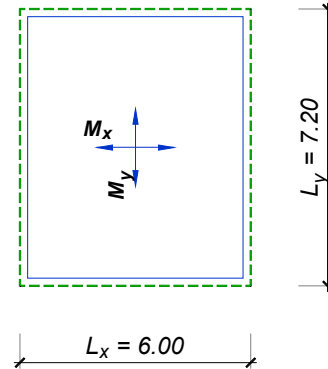

Maksimalni momenti u polju M_x , M_y

8

$$M_{yu} = M_{yu1} + M_{yu2} = 16.9 + 14.8 = 31.7 \text{ kNm/m}$$

$$a_{1y} = 2.0 + 1.2 + 1.0/2 = 3.7 \text{ cm} \Rightarrow h_y = 20 - 3.7 = 16.3 \text{ cm}$$

$$A_{ay} \approx \frac{31.7 \times 10^2}{0.9 \times 16.3 \times 40} = 5.40 \frac{\text{cm}^2}{\text{m}} \Rightarrow \text{usv.: R}\mathbf{\text{Ø10/15}} (5.24 \text{ cm}^2/\text{m})$$

Za usvojenu armaturu moguće je dokazati moment nosivosti:

$$\mu = \frac{A_a \times \sigma_v}{b \times h \times f_B} = \frac{5.24 \times 40}{100 \times 16.3 \times 2.05} = 6.268\% \Rightarrow k = 4.082$$

$$M_u = \left(\frac{16.3}{4.082} \right)^2 \times 2.05 = 32.68 \frac{\text{kNm}}{\text{m}} > 31.7 \frac{\text{kNm}}{\text{m}} = M_{yu}$$

Analiza opterećenja za grede

opterećenje sa konzolnih prepusta:

$$R_g = R_{p/2} = 5.0 \times 2.4 = 12.0 \text{ kN/m}$$

sopstvena težina greda:

$$g_{g2} = g_{g3} = 0.25 \times 0.60 \times 25 = 3.75 \text{ kN/m}$$

$$g_{g4} = 0.50 \times 0.60 \times 25 = 7.50 \text{ kN/m}$$

Simetrični deo ($g, p/2$)

$$G = P/2 = 5.0 \times 6.0 \times 7.2 = 216 \text{ kN}$$

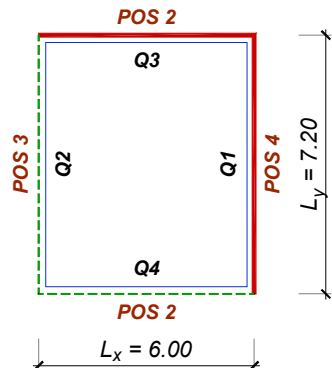

greda	k		$G = P/2$	L	$g = p_1$
			kN	m	kN/m
POS 4	0.331	Q ₁	71.5	7.2	9.93
POS 3	0.226	Q ₂	48.8	7.2	6.78
POS 2	0.257	Q ₃	55.5	6.0	9.252
POS 2	0.186	Q ₄	40.2	6.0	6.696

Analiza opterećenja za grede – simetrični deo

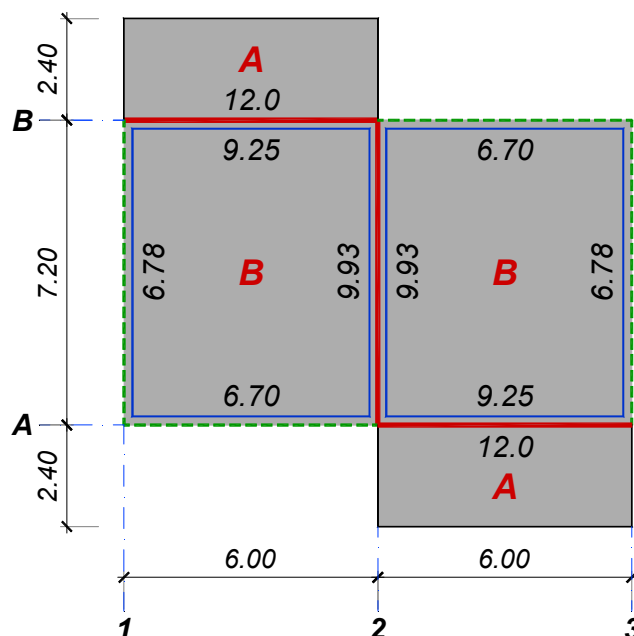

Proračun POS 2 – prvo polje

11

$$Q = 6.0 \times 7.2 \times \frac{10.0}{2} = 216 \text{ kN}$$

$$Q_2^{B2} = 0.298 \times 216 = 64.4 \text{ kN}$$

$$q_2^{B2} = \frac{64.4}{6.0} = 10.73 \frac{\text{kN}}{\text{m}}$$

$$Q_2^{B3} = -0.228 \times 216 = 49.2 \text{ kN}$$

$$q_2^{B3} = -\frac{49.2}{6.0} = -8.21 \frac{\text{kN}}{\text{m}}$$

$$g_1 = 3.75 + 12.0 + 9.25 = 25.0 \text{ kN/m}$$

$$g_2 = 3.75 + 6.70 = 10.45 \text{ kN/m}$$

$$p_1 = 12.0 + 9.25 + 12.0 + 10.73 = 43.98 \text{ kN/m}$$

$$p_2 = 6.70 + (-8.21) = -1.51 \text{ kN/m}$$

$$q_{u1} = 1.6 \times 25.0 + 1.8 \times 43.98 = 119.17 \text{ kN/m}$$

$$q_{u2} = 1.6 \times 10.45 + 1.8 \times (-1.51) = 13.99 \text{ kN/m}$$

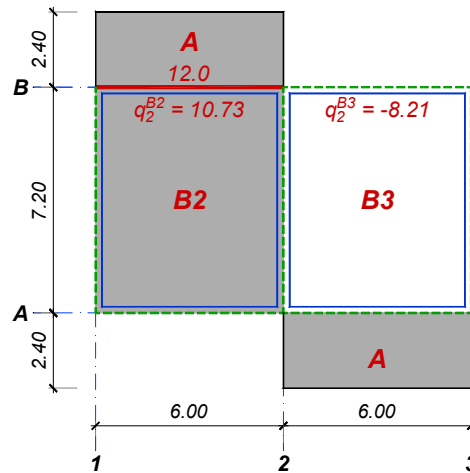

Proračun POS 2 – prvo polje

12

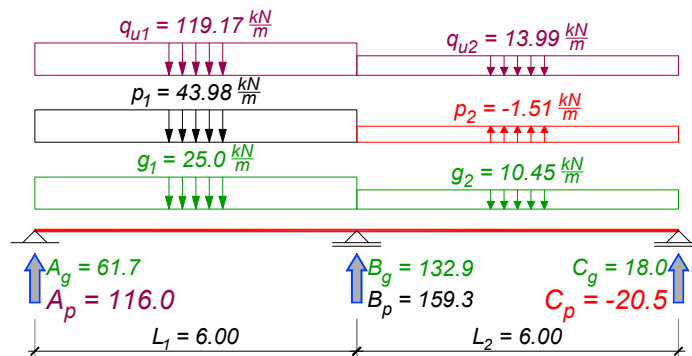

$$A_g = \frac{7 \times 25.0 - 10.45}{16} \times 6.0 = 61.7 \text{ kN}$$

$$A_p = \frac{7 \times 43.98 - (-1.51)}{16} \times 6.0 = 116.0 \text{ kN}$$

$$C_g = \frac{7 \times 10.45 - 25.0}{16} \times 6.0 = 18.0 \text{ kN}$$

$$C_p = \frac{7 \times (-1.51) - 43.98}{16} \times 6.0 = -20.5 \text{ kN}$$

$$B_g = \frac{5 \times (25.0 + 10.45)}{8} \times 6.0 = 132.9 \text{ kN}$$

Proračun POS 2 – prvo polje

13

$$A_u = 1.6 \times 61.7 + 1.8 \times 116.0 = 307.6 \text{ kN}$$

$$M_{u,\max} = \frac{A_u^2}{2 \times q_u} = \frac{307.6^2}{2 \times 119.17} = 396.9 \text{ kNm}$$

$$x_{\max} = \frac{307.6}{119.17} = 2.58 \text{ m} \Rightarrow L_0 = 2x_{\max} = 5.16 \text{ m}$$

$$B = \min \left\{ \begin{array}{l} 25 + \frac{516}{4} = 154 \\ 25 + 20 \times 20 = 425 \end{array} \right\} = 154 \text{ cm}$$

$$k = \frac{53}{\sqrt{\frac{396.9 \times 10^2}{154 \times 2.05}}} = 4.728 \Rightarrow s = 0.101 \Rightarrow x = 5.4 \text{ cm}$$

$$\varepsilon_b / \varepsilon_a = 1.128 / 10\text{‰}$$

$$\mu = 4.640\%$$

$$A_a = 4.640 \times \frac{154 \times 53}{100} \times \frac{2.05}{40} = 19.42 \text{ cm}^2$$

usvojeno **6RØ22** (22.81 cm²)

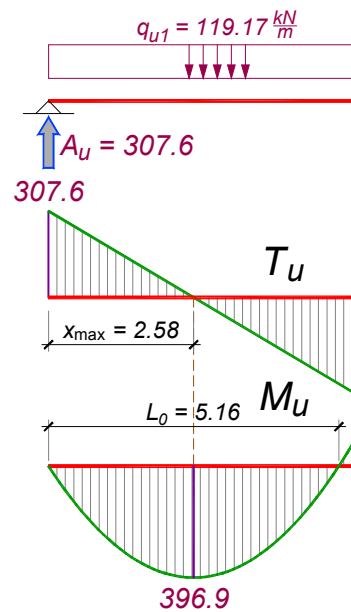

Proračun POS 2 – prvo polje

14

$$\tau_n = \frac{307.6}{25 \times 0.9 \times 53} = 0.258 \frac{\text{kN}}{\text{cm}^2} \left\{ \begin{array}{l} > \tau_r \\ < 3\tau_r \end{array} \right.$$

$$\lambda = 2.58 \times \left(1 - \frac{0.11}{0.258} \right) = 1.48 \text{ m}$$

$$\tau_{Ru}^A = \frac{3}{2} \times (0.258 - 0.11) = 0.222 \frac{\text{kN}}{\text{cm}^2}$$

$$e_u = \frac{2 \times 0.785}{25 \times 0.222} \times 40 = 11.3 \text{ cm}$$

usvojeno **URØ10/10** (m=2)

$$\Delta A_a = \frac{307.6}{2 \times 40} \times (\cot 45^\circ - \cot 90^\circ) = 3.84 \text{ cm}^2$$

usvojeno **2RØ22** (7.60 cm²)

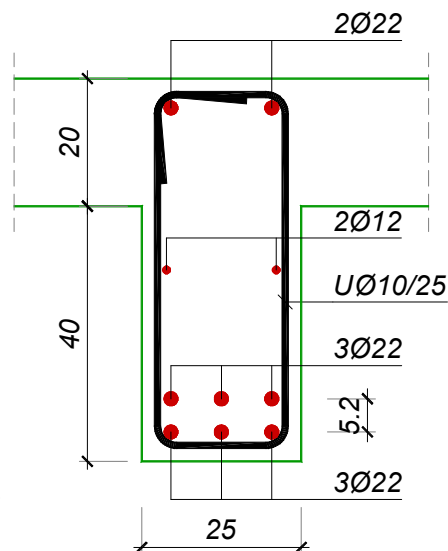

Proračun POS 2 – drugo polje

15

$$p_1 = 12.0 + 9.25 + (-12.0) + (-10.73) = -1.48 \text{ kN/m}$$

$$p_2 = 6.70 + 8.21 = 14.91 \text{ kN/m}$$

$$q_{u1} = 1.6 \times 25.0 + 1.8 \times (-1.48) = 37.35 \text{ kN/m}$$

$$q_{u2} = 1.6 \times 10.45 + 1.8 \times 14.91 = 43.54 \text{ kN/m}$$

$$C_{p,\max} = \frac{7 \times 14.91 - (-1.48)}{16} \times 6.0 = 39.7 \text{ kN}$$

$$A_{p,\min} = \frac{7 \times (-1.48) - 14.91}{16} \times 6.0 = -9.5 \text{ kN}$$

$$C_u = 1.6 \times 18.0 + 1.8 \times 39.7 = 100.3 \text{ kN}$$

$$M_{u,\max} = \frac{100.3^2}{2 \times 43.54} = 115.5 \text{ kNm}$$

$$x_{\max} = \frac{100.3}{43.54} = 2.30 \text{ m} \Rightarrow L_0 = 2 \times 2.30 = 4.60 \text{ m}$$

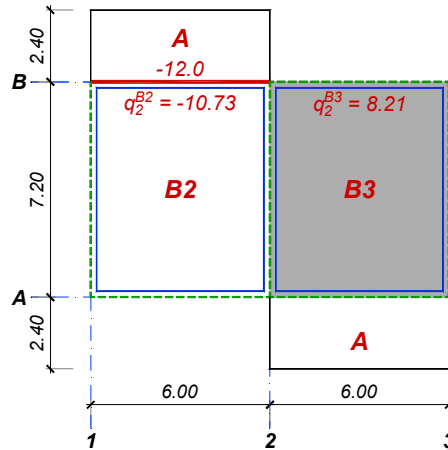

Proračun POS 2 – drugo polje

16

$$B = \min \left\{ \begin{array}{l} 25 + \frac{460}{12} = 63 \\ 25 + 8 \times 20 = 185 \end{array} \right\} = 63 \text{ cm}$$

$$k = \frac{55.5}{\sqrt{\frac{115.5 \times 10^2}{63 \times 2.05}}} = 5.887 \Rightarrow s = 0.080 \Rightarrow x = 4.4 \text{ cm}$$

$$\varepsilon_b / \varepsilon_a = 0.869 / 10\text{‰}$$

$$\bar{\mu} = 2.968\%$$

$$A_a = 2.968 \times \frac{63 \times 55.5}{100} \times \frac{2.05}{40} = 5.35 \text{ cm}^2$$

usvojeno **3RØ16** (6.03 cm²)

$$\tau_n = \frac{100.3}{25 \times 0.9 \times 53} = 0.054 \frac{\text{kN}}{\text{cm}^2} < \tau_r$$

usvojeno **URØ8/30 (15)**

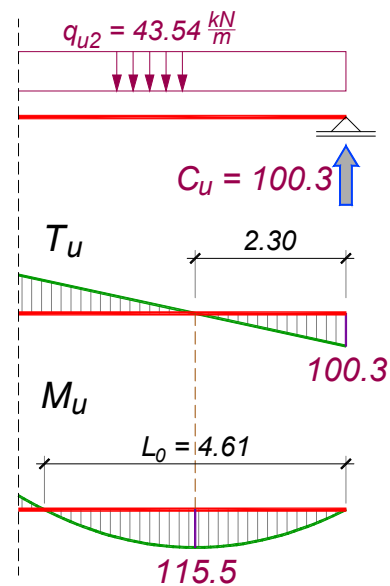

Proračun POS 2 – oslonac

17

$$Q = 6.0 \times 7.2 \times \frac{10.0}{2} = 216 \text{ kN}$$

$$q_3^B = \frac{0.257 \times 216}{6.0} = 9.25 \frac{\text{kN}}{\text{m}}$$

$$Q_3^{B1} = 0.196 \times 216 = 42.3 \text{ kN}$$

$$q_3^{B1} = \frac{42.3}{6.0} = 7.05 \frac{\text{kN}}{\text{m}}$$

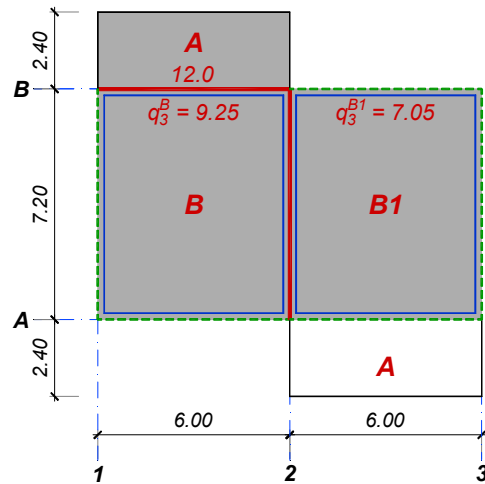

$$p_1 = 12.0 + 9.25 + 12.0 + 9.25 = 42.50 \text{ kN/m}$$

$$p_2 = 6.70 + 7.05 = 13.75 \text{ kN/m}$$

$$q_{u1} = 1.6 \times 25.0 + 1.8 \times 42.50 = 116.51 \text{ kN/m}$$

$$q_{u2} = 1.6 \times 10.45 + 1.8 \times 13.75 = 41.47 \text{ kN/m}$$

Proračun POS 2 – oslonac

18

$$A_p = \frac{7 \times 42.50 - 13.75}{16} \times 6.0 = 106.4 \text{ kN}$$

$$C_p = \frac{7 \times 13.75 - 42.50}{16} \times 6.0 = 20.2 \text{ kN}$$

$$B_{p,\max} = \frac{5 \times (42.5 + 13.75)}{8} \times 6.0 = 211.0 \text{ kN}$$

$$M_{u,\max} = - \left(\frac{q_1 L_1^2}{16} + \frac{q_2 L_2^2}{16} \right)$$

$$M_{u,\max} = - \frac{116.51 + 41.47}{16} \times 6.0^2 = -355.4 \text{ kNm}$$

$$k = \frac{53}{\sqrt{\frac{355.4 \times 10^2}{25 \times 2.05}}} = 2.012 \Rightarrow \begin{aligned} \epsilon_b / \epsilon_a &= 3.5 / 6.264\% \\ \bar{\mu} &= 29.017\% \end{aligned}$$

$$A_a = 29.017 \times \frac{25 \times 53}{100} \times \frac{2.05}{40} = 19.70 \text{ cm}^2 \Rightarrow \text{usvojeno } 6R\text{Ø}22 \text{ (22.81 cm}^2\text{)}$$

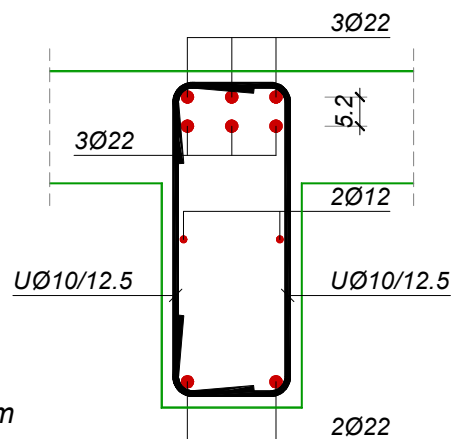

Proračun POS 2 – oslonac

19

$$A_u = 1.6 \times 61.7 + 1.8 \times 106.4 = 290.3 \text{ kN}$$

$$T_u^{B,I} = A_u - q_{u1} \times L_1$$

$$T_u^{B,I} = 290.3 - 116.51 \times 6.0 = -408.8 \text{ kN}$$

$$\tau_n^{B,I} = \frac{408.8}{25 \times 0.9 \times 53} = 0.343 \frac{\text{kN}}{\text{cm}^2} > 3\tau_r$$

$$x_1 = \frac{290.3}{116.51} = 2.49 \text{ m}$$

$$\lambda = (6.0 - 2.49) \times \left(1 - \frac{0.11}{0.343}\right) = 2.38 \text{ m}$$

$$e_u = \frac{2 \times 0.785}{25 \times 0.343} \times 40 = 7.3 \text{ cm} \Rightarrow \text{usvojeno } \mathbf{U2R\text{\O}10/12.5}$$

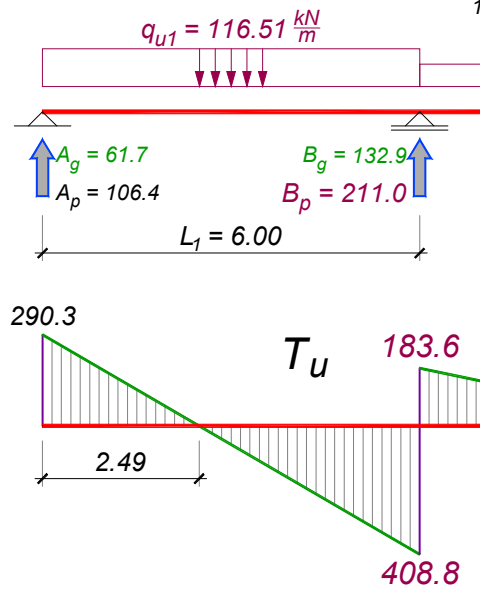

Proračun POS 2 – oslonac

20

$$x = 3.51 \times \left(1 - \frac{0.33}{0.343}\right) = 0.131 \text{ m}$$

Jednostruke uzengije **UR\O10/12.5** mogu prihvatiti napon:

$$\tau_{u,u}^{(1)} = \frac{2 \times 0.785}{25 \times 12.5} \times 40 = 0.201 \frac{\text{kN}}{\text{cm}^2}$$

i dovoljne su na dužini:

$$\lambda_1 = \frac{\tau_{u,u}^{(1)}}{3\tau_r} (\lambda - x) = \frac{0.201}{0.33} \times (2.38 - 0.131) = 1.37 \text{ m}$$

dok je na preostalom delu dužine osiguranja $2.38 - 1.37 = 1.01 \text{ m}$ potrebno postaviti dvostruke uzengije (ili, kao varijantno rešenje, vertikalne uzengije i koso povijene profile).

$$\Delta A_a = 0 \text{ (»špic« momenta)}$$

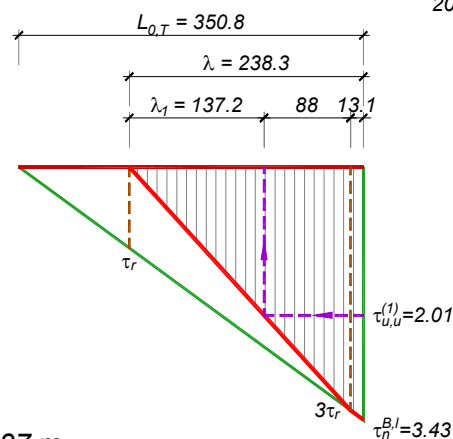

Proračun POS 2 – oslonac

21

$$C_u = 1.6 \times 18.0 + 1.8 \times 20.2 = 65.2 \text{ kN}$$

$$T_u^{B,d} = q_{u2} \times L_2 - C_u$$

$$T_u^{B,d} = 41.47 \times 6.0 - 65.2 = 183.6 \text{ kN}$$

$$\tau_n^{B,d} = \frac{183.6}{25 \times 0.9 \times 53} = 0.154 \frac{\text{kN}}{\text{cm}^2}$$

$$x_2 = \frac{65.2}{41.47} = 1.57 \text{ m}$$

$$\lambda = (6.0 - 1.57) \times \left(1 - \frac{0.11}{0.154}\right) = 1.27 \text{ m}$$

$$\tau_{Ru}^{B,d} = \frac{3}{2} \times (0.154 - 0.11) = 0.066 \frac{\text{kN}}{\text{cm}^2}$$

$$e_u = \frac{2 \times 0.503}{25 \times 0.2\%} = 20.1 \text{ cm} \Rightarrow \text{usvojeno } \mathbf{UR\text{Ø}8/20}$$

$$\Delta A_a = 0$$

$$\tau_{u,u} = \frac{2 \times 0.503}{25 \times 20} \times 40 = 0.080 \frac{\text{kN}}{\text{cm}^2} > \tau_{Ru,\max} = 0.066 \frac{\text{kN}}{\text{cm}^2}$$

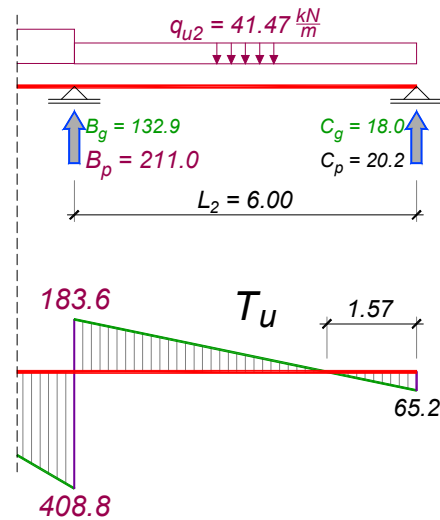

Proračun POS 3

22

$$Q_1^{B3} = 0.272 \times 216 = 58.8 \text{ kN}$$

$$q_1^{B3} = \frac{58.8}{7.2} = 8.16 \frac{\text{kN}}{\text{m}}$$

$$g = 3.75 + 6.78 = 10.53 \text{ kN/m}$$

$$p = 6.78 + 8.16 = 14.94 \text{ kN/m}$$

$$q_u = 1.6 \times 10.53 + 1.8 \times 14.94 = 43.74 \text{ kN/m}$$

$$M_u = 43.74 \times 7.2^2 / 8 = 283.4 \text{ kNm}$$

$$B = 25 + \frac{720}{12} = 85 \text{ cm}$$

$$\varepsilon_b / \varepsilon_a = 1.326 / 10\%$$

$$k = \frac{53}{\sqrt{\frac{283.4 \times 10^2}{85 \times 2.05}}} = 4.156 \Rightarrow s = 0.117 \Rightarrow x = 0.117 \times 53 = 6.2 \text{ cm} < d_p = 20 \text{ cm}$$

$$\bar{\mu} = 6.043\%$$

$$A_a = 6.043 \times \frac{85 \times 53}{100} \times \frac{2.05}{40} = 13.95 \text{ cm}^2 \Rightarrow \text{usvojeno } \mathbf{4R\text{Ø}22} (15.21 \text{ cm}^2)$$

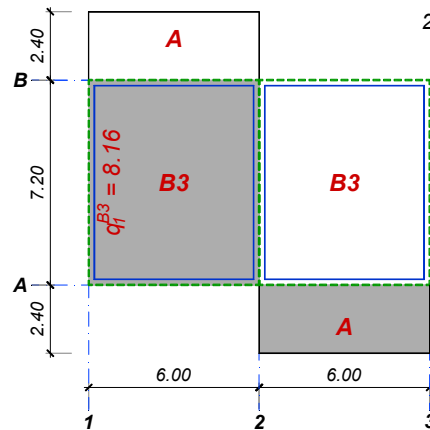

Proračun POS 3

23

$$T_u = 1.6 \times 37.9 + 1.8 \times 53.8 = 157.5 \text{ kN}$$

$$\tau_n = \frac{157.5}{25 \times 0.9 \times 53} = 0.132 \frac{\text{kN}}{\text{cm}^2} \Rightarrow \lambda = \frac{7.2}{2} \times \left(1 - \frac{0.11}{0.132}\right) = 0.60 \text{ m}$$

$$\tau_{Ru} = \frac{3}{2} \times (0.132 - 0.11) = 0.033 \frac{\text{kN}}{\text{cm}^2}$$

$$e_u = \frac{2 \times 0.503}{25 \times 0.2\%} = 20.1 \text{ cm} \Rightarrow \text{usvojeno } \mathbf{UR\emptyset 8/20}$$

$$\tau_{u,u} = \frac{2 \times 0.503}{25 \times 20} \times 40 = 0.080 \frac{\text{kN}}{\text{cm}^2} > \tau_{Ru,max} = 0.033 \frac{\text{kN}}{\text{cm}^2}$$

$$\Delta A_a = \frac{157.5}{2 \times 40} \times (\cot 45^\circ - \cot 90^\circ) = 1.97 \text{ cm}^2 \Rightarrow \text{usvojeno } \mathbf{2R\emptyset 22} \text{ (7.60 cm}^2\text{)}$$

Proračun POS 4

24

$$Q_r^{B1} = 0.362 \times 216 = 78.2 \text{ kN}$$

$$q_1^{B1} = \frac{78.2}{7.2} = 10.86 \frac{\text{kN}}{\text{m}}$$

$$g = 7.5 + 2 \times 9.93 = 27.36 \text{ kN/m}$$

$$p = 2 \times (9.93 + 10.86) = 41.58 \text{ kN/m}$$

$$q_u = 1.6 \times 27.36 + 1.8 \times 41.58 = 118.62 \text{ kN/m}$$

$$M_u = 118.62 \times 7.2^2 / 8 = 768.7 \text{ kNm}$$

$$B = 50 + \frac{720}{4} = 230 \text{ cm}$$

$$\varepsilon_b / \varepsilon_a = 1.327 / 10\%$$

$$k = \frac{53}{\sqrt{\frac{768.7 \times 10^2}{230 \times 2.05}}} = 4.151 \Rightarrow s = 0.117 \Rightarrow x = 0.117 \times 53 = 6.2 \text{ cm} < d_p = 20 \text{ cm}$$

$$\bar{\mu} = 6.057\%$$

$$A_a = 6.057 \times \frac{230 \times 53}{100} \times \frac{2.05}{40} = 37.84 \text{ cm}^2 \Rightarrow \text{usvojeno } \mathbf{10R\emptyset 22} \text{ (38.01 cm}^2\text{)}$$

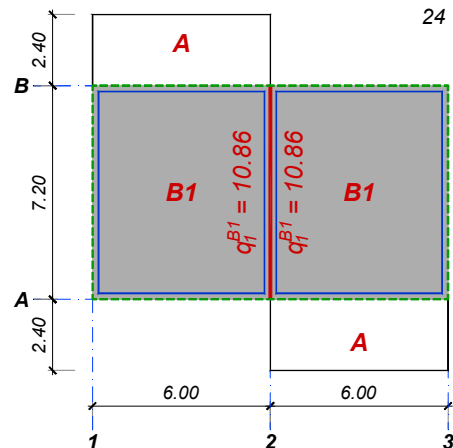

Proračun POS 4

25

$$T_u = 1.6 \times 98.5 + 1.8 \times 149.7 = 427.0 \text{ kN}$$

$$\tau_n = \frac{427.0}{50 \times 0.9 \times 53} = 0.179 \frac{\text{kN}}{\text{cm}^2} \begin{cases} > \tau_r = 1.1 \text{ MPa} \\ < 3\tau_r \end{cases}$$

$$\lambda = \frac{7.2}{2} \times \left(1 - \frac{0.11}{0.179}\right) = 1.39 \text{ m}$$

$$\tau_{Ru} = \frac{3}{2} \times (0.179 - 0.11) = 0.104 \frac{\text{kN}}{\text{cm}^2}$$

$$e_u = \frac{2 \times 0.785}{50 \times 0.104} \times 40 = 12.1 \text{ cm}$$

usvojeno **URØ10/10** (m=2)

$$\Delta A_a = \frac{427.0}{2 \times 40} \times (\cot 45^\circ - \cot 90^\circ) = 5.34 \text{ cm}^2$$

usvojeno **4RØ22** (15.21 cm²)

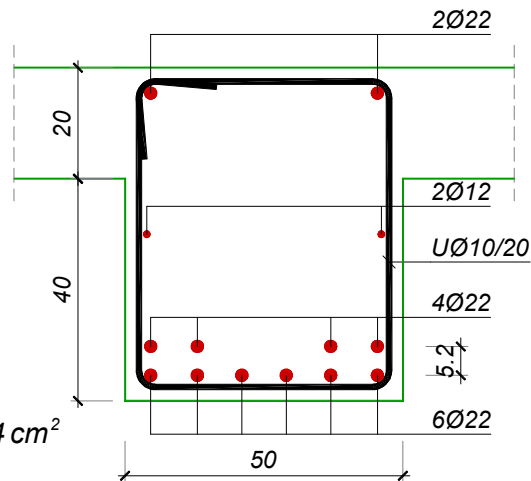

Vetar u podužnom pravcu - W_x

26

W_x prihvataju dva rama jednake krutosti (ose A i B)

$$J_{s1} = J_{s3} ; J_{s2} = \left(\frac{50}{25}\right)^3 \times J_{s1} = 8J_{s1}$$

$$W_{x1} + 8W_{x1} + W_{x1} = 10W_{x1} = \frac{W_x}{2} = 80 \text{ kN} \Rightarrow \begin{cases} W_{x1} = 8.0 \text{ kN} \\ W_{x2} = 64.0 \text{ kN} \end{cases}$$

$$M_{W_{x,1}} \approx \frac{W_{x1} H}{2} = M_{W_{x,3}}$$

$$M_{W_{x,1}} \approx \frac{8.0 \times 5.0}{2} = 20 \text{ kNm}$$

$$M_{W_{x,2}} \approx \frac{W_{x2} H}{2}$$

$$M_{W_{x,2}} \approx \frac{64.0 \times 5.0}{2} = 160 \text{ kNm}$$

$$A_w = -C_w = \frac{20 + 80}{6} = 16.7 \text{ kN}$$

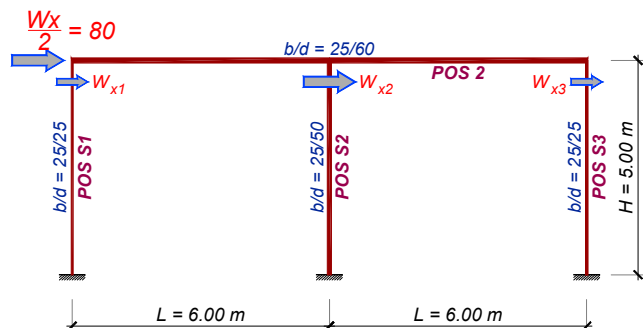

Vetar u podužnom pravcu - W_x

27

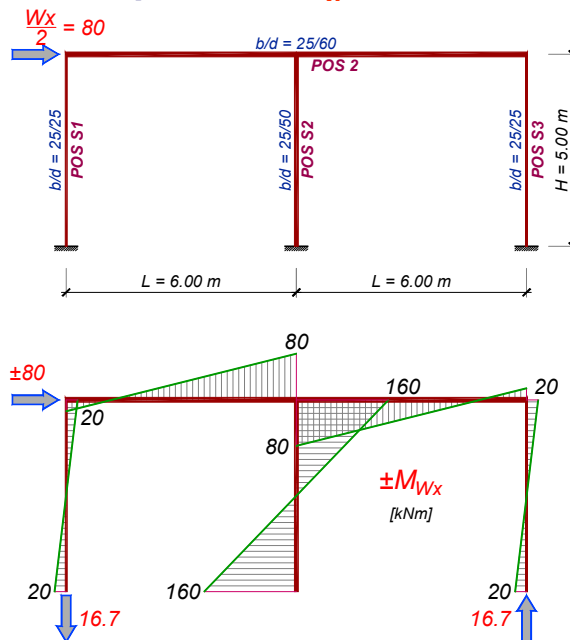

Vetar u poprečnom pravcu - W_y

28

Vetar W_y prihvataju tri rama, od kojih su ivični ramovi (u osama 1 i 3) širine 25 cm, a srednji ram (osa 2) širine 50 cm, dakle dvaput veće krutosti. Stoga srednji ram prihvata polovinu, a ivični po četvrtinu ukupne sile:

$$W_y^1 + W_y^2 + W_y^3 = W_y^1 + 2W_y^1 + W_y^1 = 4W_y^1$$

$$4W_y^1 = W_y = 160 \text{ kN} \Rightarrow W_y^1 = 40 \text{ kN} = W_y^3 ; W_y^2 = 80 \text{ kN}$$

Svaki ram formiraju po dva stuba istog preseka, visine i konturnih uslova, pa svaki stub prihvata polovinu odgovarajuće sile od vetra:

$$M_{W_y,2} \approx \frac{80}{2} \times \frac{5.0}{2} = 100 \text{ kNm} \quad A_w = -B_w = \frac{100 + 100}{7.2} = 27.8 \text{ kN} \quad (\text{S2})$$

$$M_{W_y,1} \approx \frac{40}{2} \times \frac{5.0}{2} = 50 \text{ kNm} = M_{W_y,3} \quad A_w = -B_w = \frac{50 + 50}{7.2} = 13.9 \text{ kN} \quad (\text{S1, S3})$$

Vetar u poprečnom pravcu - W_y

29

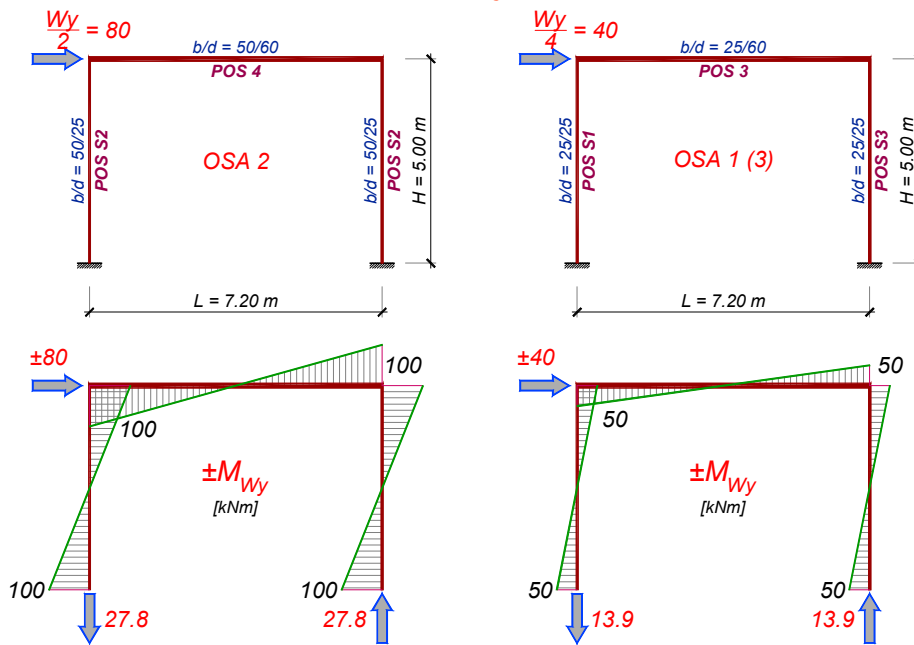

Dimenzionisanje stubova S1, S3

30

Maksimalna sila usled p u stubu S1, istovremeno i minimalna sila u stubu S3:

$$q_1^{B2} = \frac{Q_1^{B2}}{L_y} = \frac{0.244 \times 216}{7.2} = 7.32 \frac{\text{kN}}{\text{m}}$$

$$p_{\max}^{\text{POS3}} = 6.78 + 7.32 = 14.1 \text{ kN/m}$$

$$R_{p,\max}^{\text{POS3}} = 14.1 \times 7.2 / 2 = 50.8 \text{ kN}$$

$$P_{\max} = A_{p,\max}^{\text{POS2}} + R_{p,\max}^{\text{POS3}} = 116 + 50.8 = 166.8 \text{ kN}$$

$$p_{\min}^{\text{POS3}} = 6.78 - 8.16 = -1.38 \text{ kN/m}$$

$$R_{p,\min}^{\text{POS3}} = -1.38 \times 7.2 / 2 = -5.0 \text{ kN}$$

$$P_{\min} = C_{p,\min}^{\text{POS2}} + R_{p,\min}^{\text{POS3}} = -20.5 - 5.0 = -25.5 \text{ kN}$$

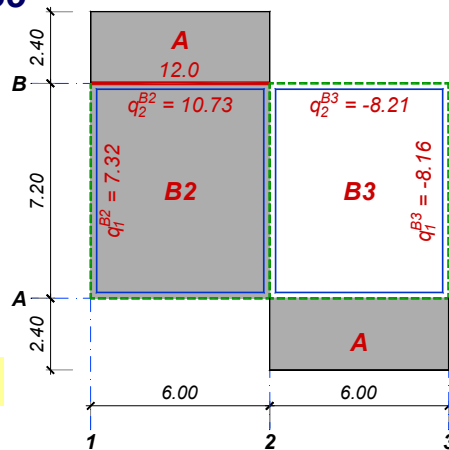

Dimenzionisanje stubova S1, S3

31

Ukupna sila u POS S1 i S3 se dobija sabiranjem reakcija POS 2 i POS 3:

$$\text{stub POS S1: } G = A_{g2} + R_{g3} = 61.7 + 37.9 = 99.6 \text{ kN}$$

$$\text{stub POS S3: } G = C_{g2} + R_{g3} = 18.0 + 37.9 = 55.9 \text{ kN}$$

Podužni pravac (vetar W_x) – b/d = 25/25 cm

$$\pm M_u = 1.8 \times 20 = 36 \text{ kNm} \quad \Rightarrow \quad m_u = \frac{36 \times 10^2}{25 \times 25^2 \times 2.05} = 0.112$$

$$N_{u,\min} = 1.0 \times G + 1.8 \times (P_{\min} + Z_w) = 1.0 \times 55.9 + 1.8 \times (-25.5 - 16.7) = -19.8 \text{ kN}$$

$$n_u = \frac{-19.8 \times 10^2}{25 \times 25 \times 2.05} = -0.015 \quad \Rightarrow \quad \bar{\mu}_1 = 0.16$$

$$N_{u,\max} = 1.6 \times G + 1.8 \times (P_{\max} + N_w) = 1.6 \times 99.6 + 1.8 \times (166.8 + 16.7) = 489.6 \text{ kN}$$

$$n_u = \frac{489.6 \times 10^2}{25 \times 25 \times 2.05} = 0.382 \quad \Rightarrow \quad \bar{\mu}_1 = 0$$

$$A_{a1} = A_{a2} = 0.16 \times 25 \times 25 \times \frac{2.05}{40} = 5.12 \text{ cm}^2$$

Dimenzionisanje stubova S1, S3

32

Poprečni pravac (vetar W_y) – b/d = 25/25 cm

$$\pm M_u = 1.8 \times 50 = 90 \text{ kNm} \quad \Rightarrow \quad m_u = \frac{90 \times 10^2}{25 \times 25^2 \times 2.05} = 0.281$$

$$N_{u,\min} = 1.0 \times G + 1.8 \times (P_{\min} + Z_w) \quad (\text{POS S3})$$

$$N_{u,\min} = 1.0 \times 55.9 + 1.8 \times (-25.5 - 13.9) = -14.8 \text{ kN}$$

$$n_u = \frac{-14.8 \times 10^2}{25 \times 25 \times 2.05} = -0.012 \quad \Rightarrow \quad \bar{\mu}_1 = 0.421$$

$$N_{u,\max} = 1.6 \times G + 1.8 \times (P_{\max} + N_w) \quad (\text{POS S1})$$

$$N_{u,\max} = 1.6 \times 99.6 + 1.8 \times (166.8 + 13.9) = 484.6 \text{ kN}$$

$$n_u = \frac{484.6 \times 10^2}{25 \times 25 \times 2.05} = 0.378 \quad \Rightarrow \quad \bar{\mu}_1 = 0.258$$

$$A_{a1} = A_{a2} = 0.421 \times 25 \times 25 \times \frac{2.05}{40} = 13.47 \text{ cm}^2$$

Dimenzionisanje stubova S2

33

$$q_1^{B1} = \frac{Q_1^{B1}}{L_y} = \frac{0.362 \times 216}{7.2} = 10.86 \frac{\text{kN}}{\text{m}}$$

$$p_{\text{max}}^{\text{POS4}} = 2 \times 9.93 + 9.93 + 10.86 = 40.65 \text{ kN/m}$$

$$R_{p,\text{max}}^{\text{POS4}} = 40.65 \times 7.2 / 2 = 146.3 \text{ kN}$$

$$P_{\text{max}} = B_{p,\text{max}}^{\text{POS2}} + R_{p,\text{max}}^{\text{POS4}} = 211 + 146.3 = 357.3 \text{ kN}$$

$$p_{\text{min}}^{\text{POS4}} = 2 \times 9.93 - 9.93 - 10.86 = -0.93 \text{ kN/m}$$

$$R_{p,\text{min}}^{\text{POS4}} = -0.93 \times 7.2 / 2 = -3.3 \text{ kN}$$

$$p_{1,\text{min}}^{\text{POS2}} = 12 + 9.25 - 12 - 9.25 = 0$$

$$p_{2,\text{min}}^{\text{POS2}} = 6.70 - 7.05 = -0.35 \text{ kN/m}$$

$$B_{p,\text{min}} = \frac{5 \times (0 - 0.35)}{8} \times 6.0 = -1.4 \text{ kN}$$

$$P_{\text{min}} = B_{p,\text{min}}^{\text{POS2}} + R_{p,\text{min}}^{\text{POS4}} = -1.4 - 3.3 = -4.7 \text{ kN}$$

$$G = B_{g2} + R_{g4} = 132.9 + 98.5 = 231.4 \text{ kN}$$

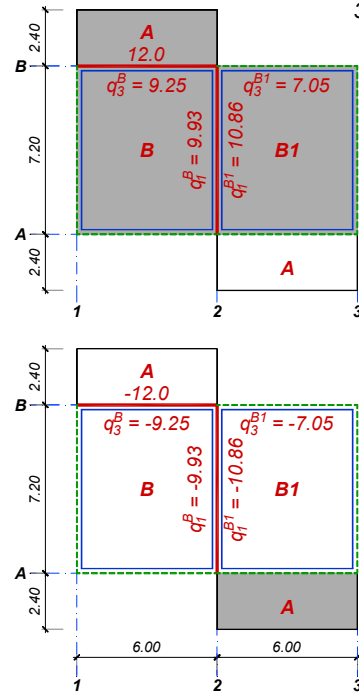

Dimenzionisanje stubova S2

34

Poprečni pravac (vetar W_y) – $b/d = 50/25 \text{ cm}$

$$\pm M_u = 1.8 \times 100 = 180 \text{ kNm} \Rightarrow m_u = \frac{180 \times 10^2}{50 \times 25^2 \times 2.05} = 0.281$$

$$N_{u,\text{min}} = 1.0G + 1.8(P_{\text{min}} + Z_w)$$

$$N_{u,\text{min}} = 1.0 \times 231.4 + 1.8 \times (-4.7 - 27.8) = 173.0 \text{ kN}$$

$$n_u = \frac{173.0 \times 10^2}{50 \times 25 \times 2.05} = 0.068 \Rightarrow \bar{\mu}_1 = 0.382$$

$$N_{u,\text{max}} = 1.6G + 1.8(P_{\text{max}} + N_w)$$

$$N_{u,\text{max}} = 1.6 \times 231.4 + 1.8 \times (357.3 + 27.8) = 1063.4 \text{ kN}$$

$$n_u = \frac{1063.4 \times 10^2}{50 \times 25 \times 2.05} = 0.415 \Rightarrow \bar{\mu}_1 = 0.253$$

$$A_{a1} = A_{a2} = 0.382 \times 50 \times 25 \times \frac{2.05}{40} = 24.48 \text{ cm}^2$$

Dimenzionisanje stubova S2

35

Podužni pravac (vetar W_x) – $b/d = 25/50$ cm

$$\pm M_u = 1.8 \times 160 = 288 \text{ kNm} \Rightarrow m_u = \frac{288 \times 10^2}{25 \times 50^2 \times 2.05} = 0.225$$

$$N_{u,\min} = 1.0 \times G + 1.8 \times P_{\min} = 1.0 \times 231.4 + 1.8 \times (-4.7) = 223.0 \text{ kN}$$

$$n_u = \frac{223.0 \times 10^2}{25 \times 50 \times 2.05} = 0.087 \Rightarrow \bar{\mu}_1 = 0.228$$

$$N_{u,\max} = 1.6 \times G + 1.8 \times P_{\max} = 1.6 \times 231.4 + 1.8 \times 357.3 = 1013.4 \text{ kN}$$

$$n_u = \frac{1013.4 \times 10^2}{25 \times 50 \times 2.05} = 0.395 \Rightarrow \bar{\mu}_1 = 0.131$$

$$A_{a1} = A_{a2} = 0.228 \times 25 \times 50 \times \frac{2.05}{40} = 14.62 \text{ cm}^2$$

36

2

1 (3)

Ugaoni stubovi (POS S1, POS S3):

$$A_{a1,x} = 2R\emptyset 25 = 9.82 \text{ cm}^2 > A_{a,\text{potr.}} = 5.12 \text{ cm}^2$$

$$A_{a1,y} = 3R\emptyset 25 = 14.73 \text{ cm}^2 > A_{a,\text{potr.}} = 13.47 \text{ cm}^2$$

Srednji stubovi (POS S2):

$$A_{a1,x} = 3R\emptyset 25 = 14.73 \text{ cm}^2 > A_{a,\text{potr.}} = 14.62 \text{ cm}^2$$

$$A_{a1,y} = 5R\emptyset 25 = 24.54 \text{ cm}^2 > A_{a,\text{potr.}} = 24.48 \text{ cm}^2$$