

Dispozicija hale

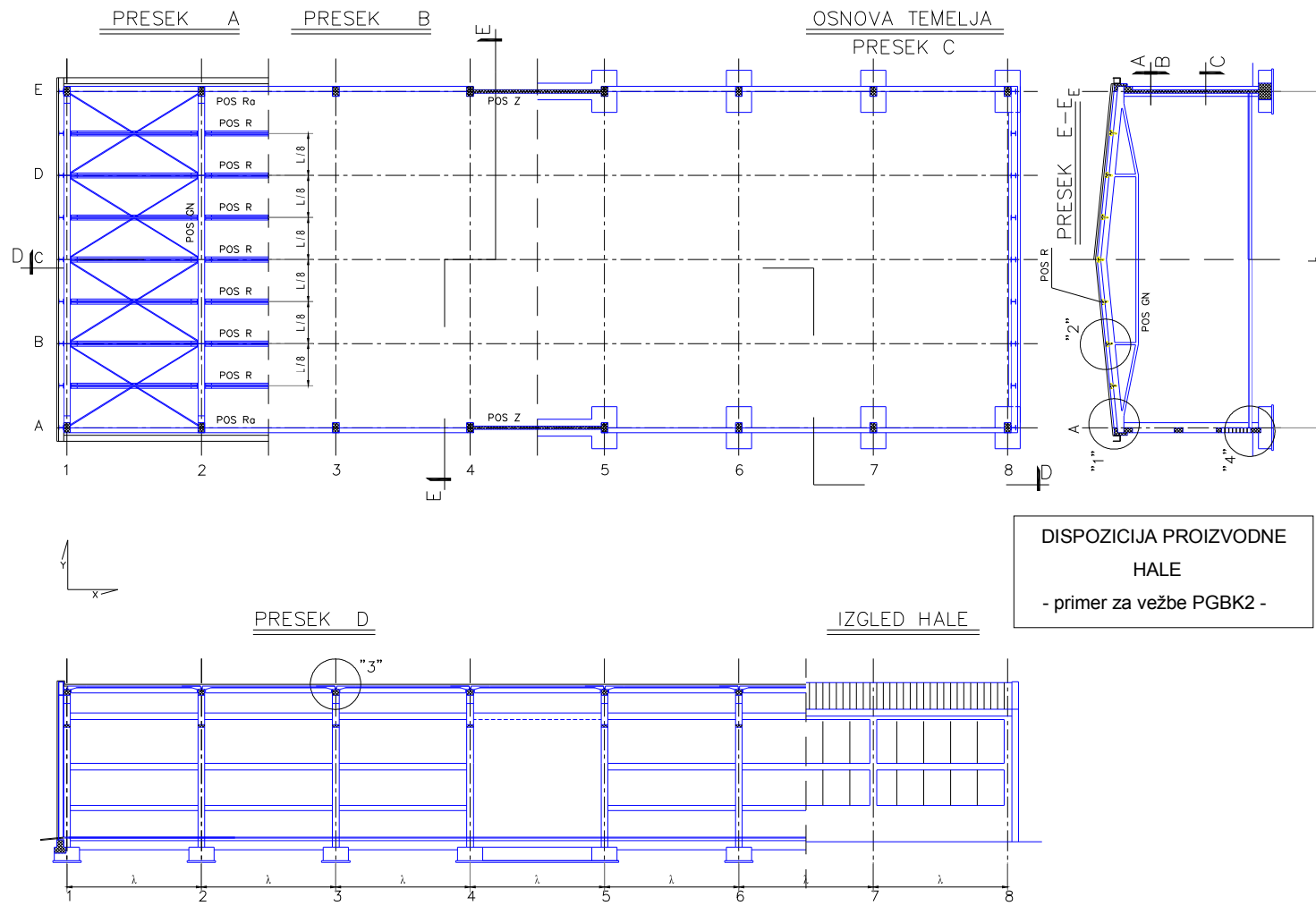

Glavni nosač

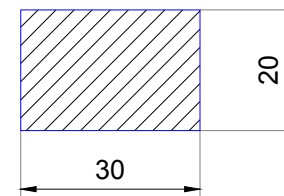

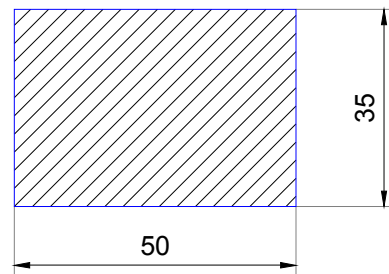
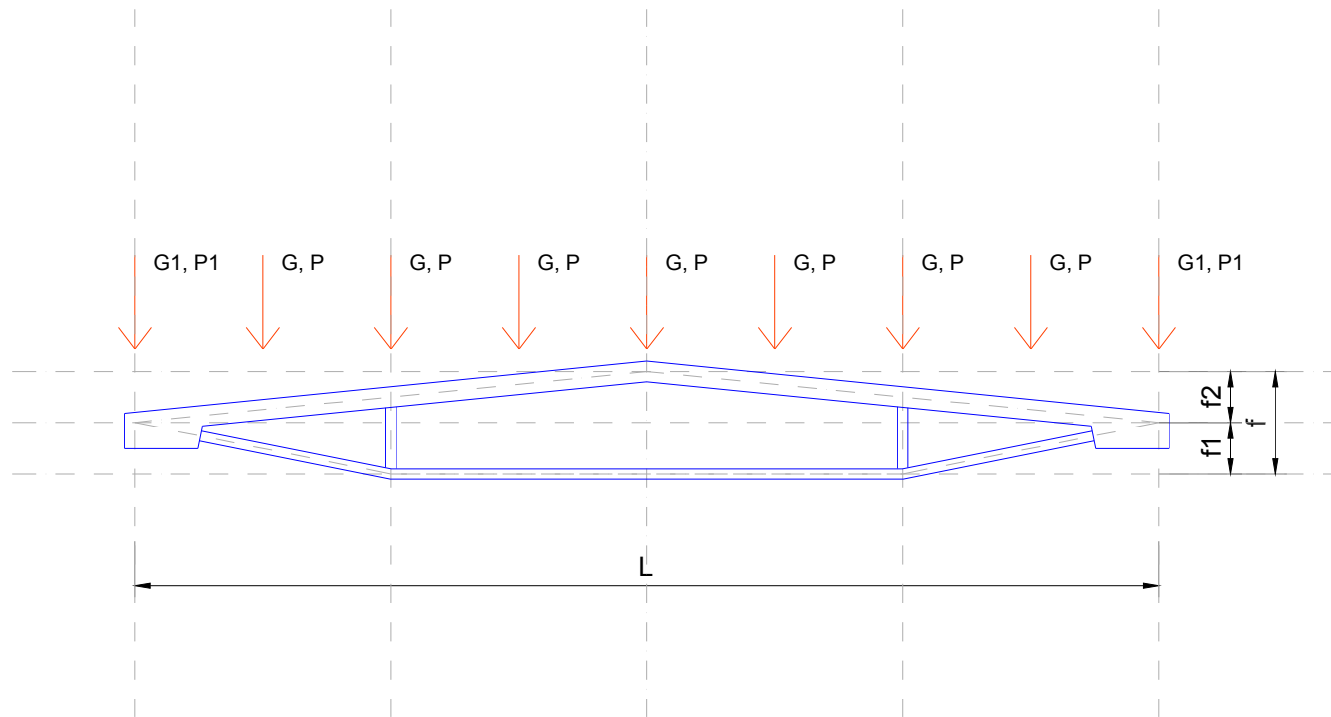
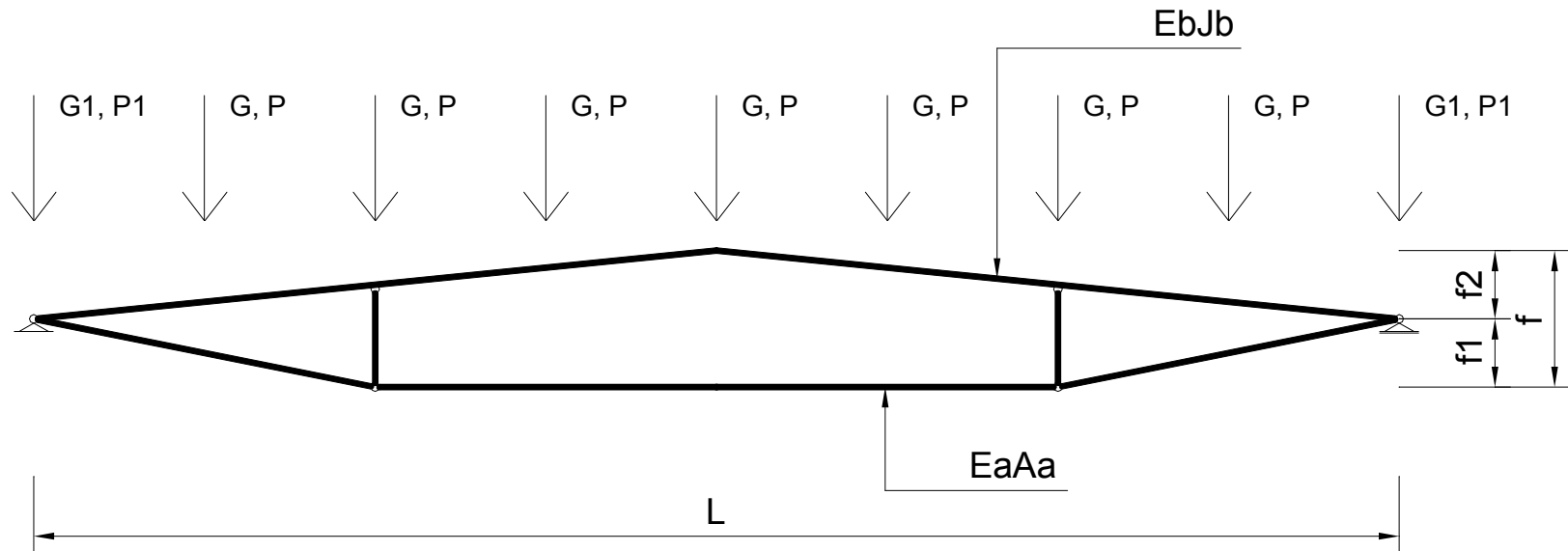

$$G = 2R_g^{POSR} \Rightarrow g = G/(L/8)$$

$$P = 2R_p^{POSR} \Rightarrow p = P/(L/8)$$

$$q_u = 1.6 \cdot g + 1.8 \cdot p \Rightarrow M_u = q_u L^2 / 8$$

$$A_a \approx \frac{M_u}{f \cdot \sigma_v}$$

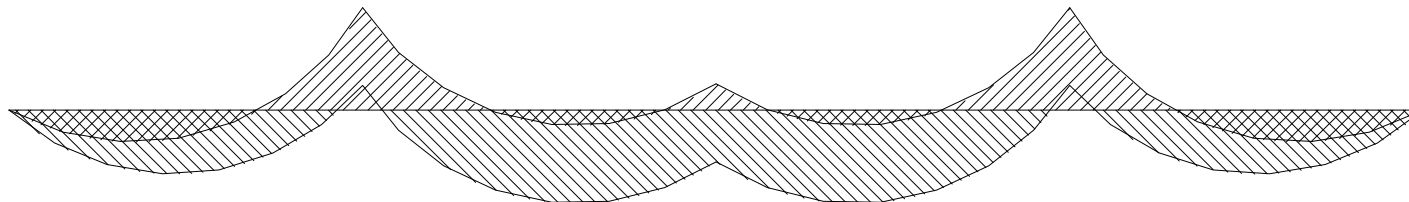

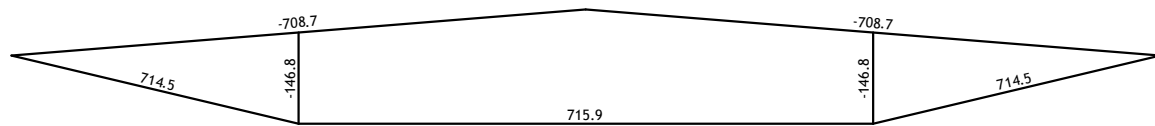
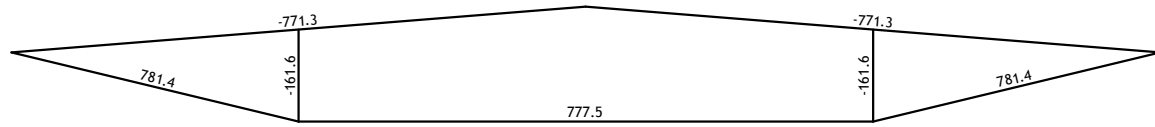
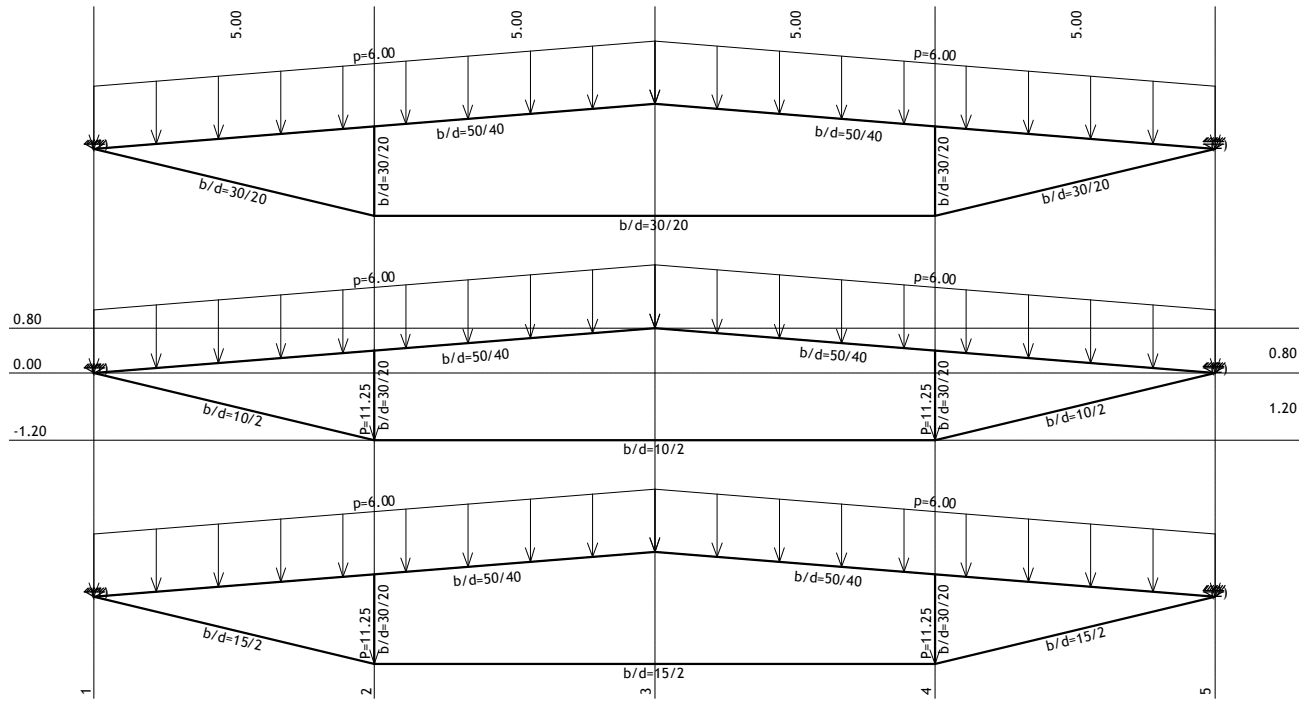

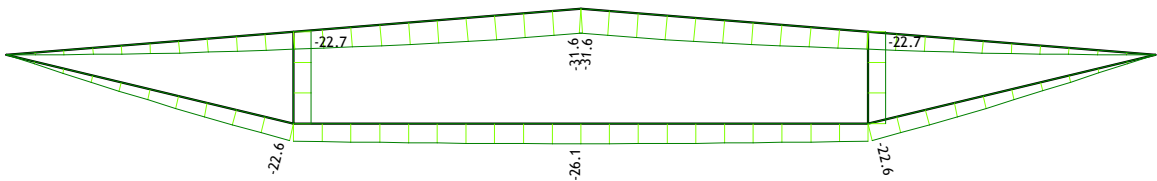
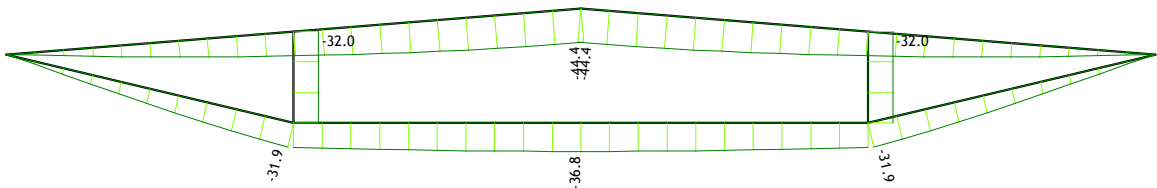
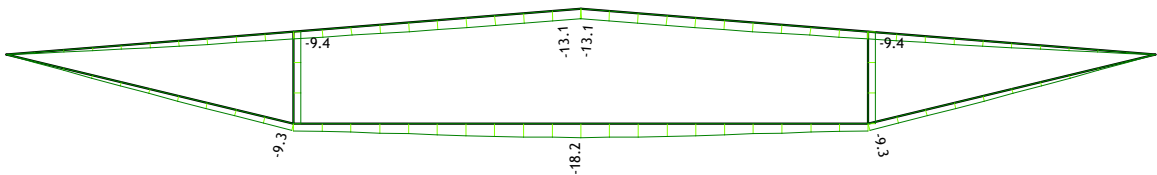
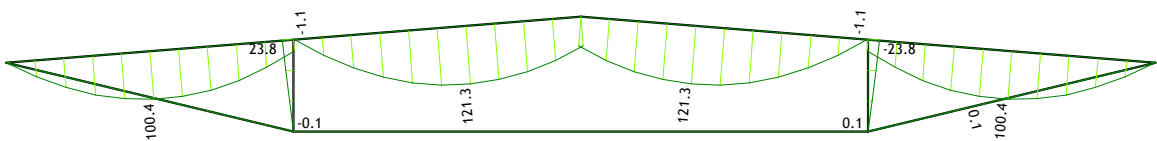
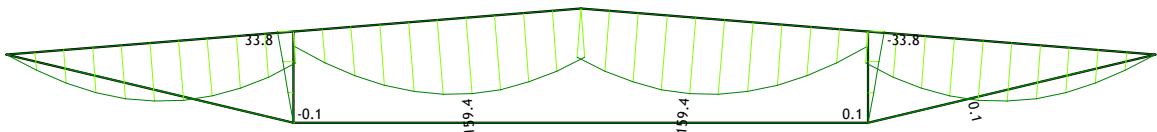
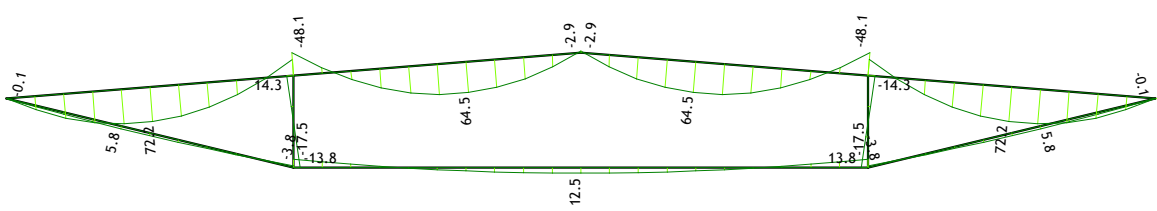

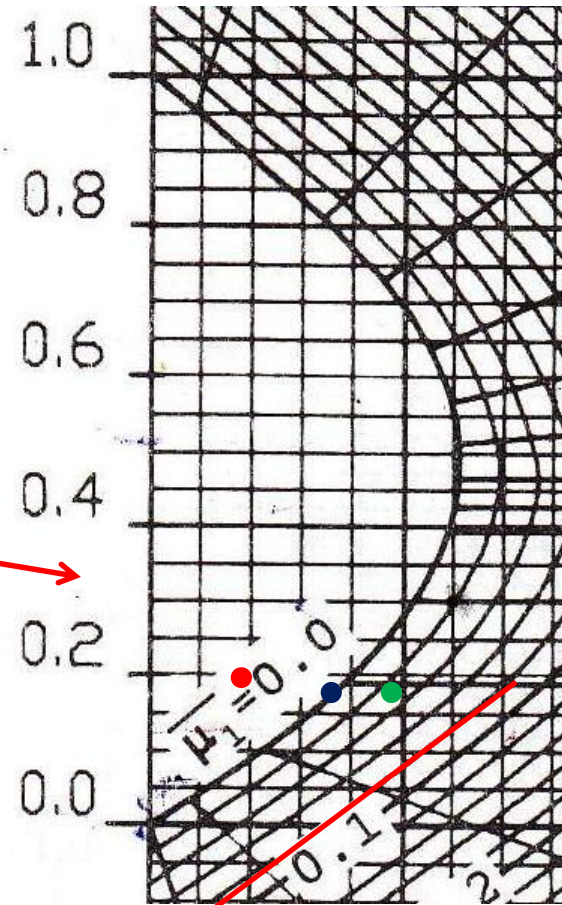
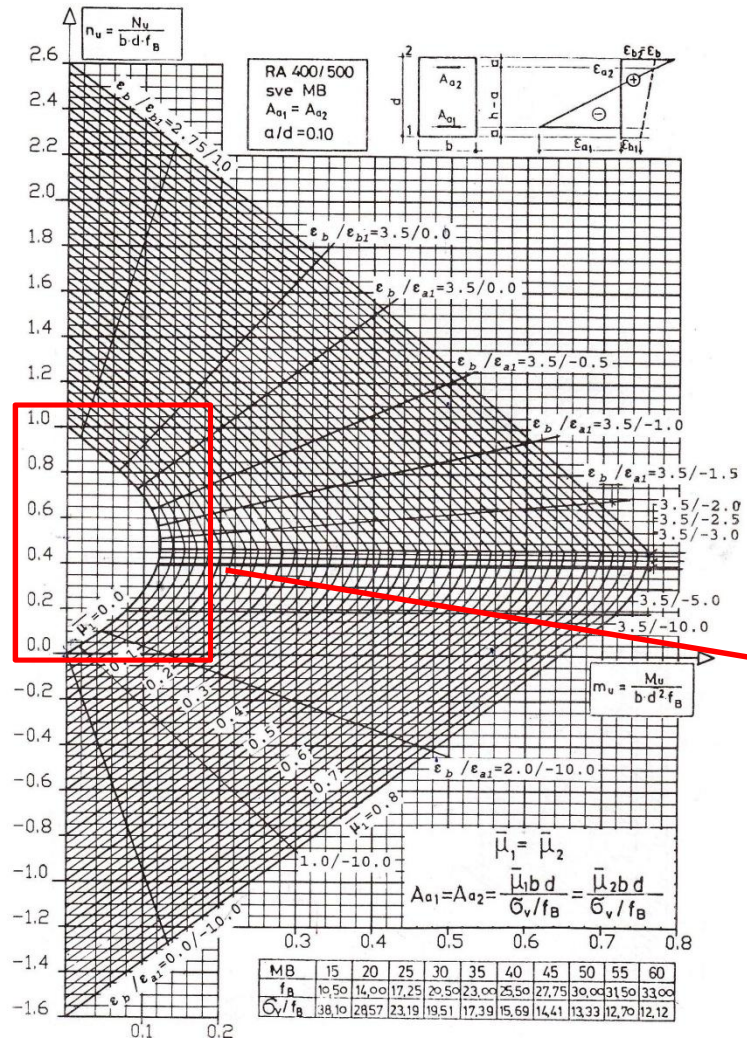

min μ

M_u	N_u	m_u	n_u
64.5	777.5	0.039	0.190
159.4	715.9	0.097	0.175
121.3	736.7	0.074	0.180

-
-
-

Varijante glavnih nosača

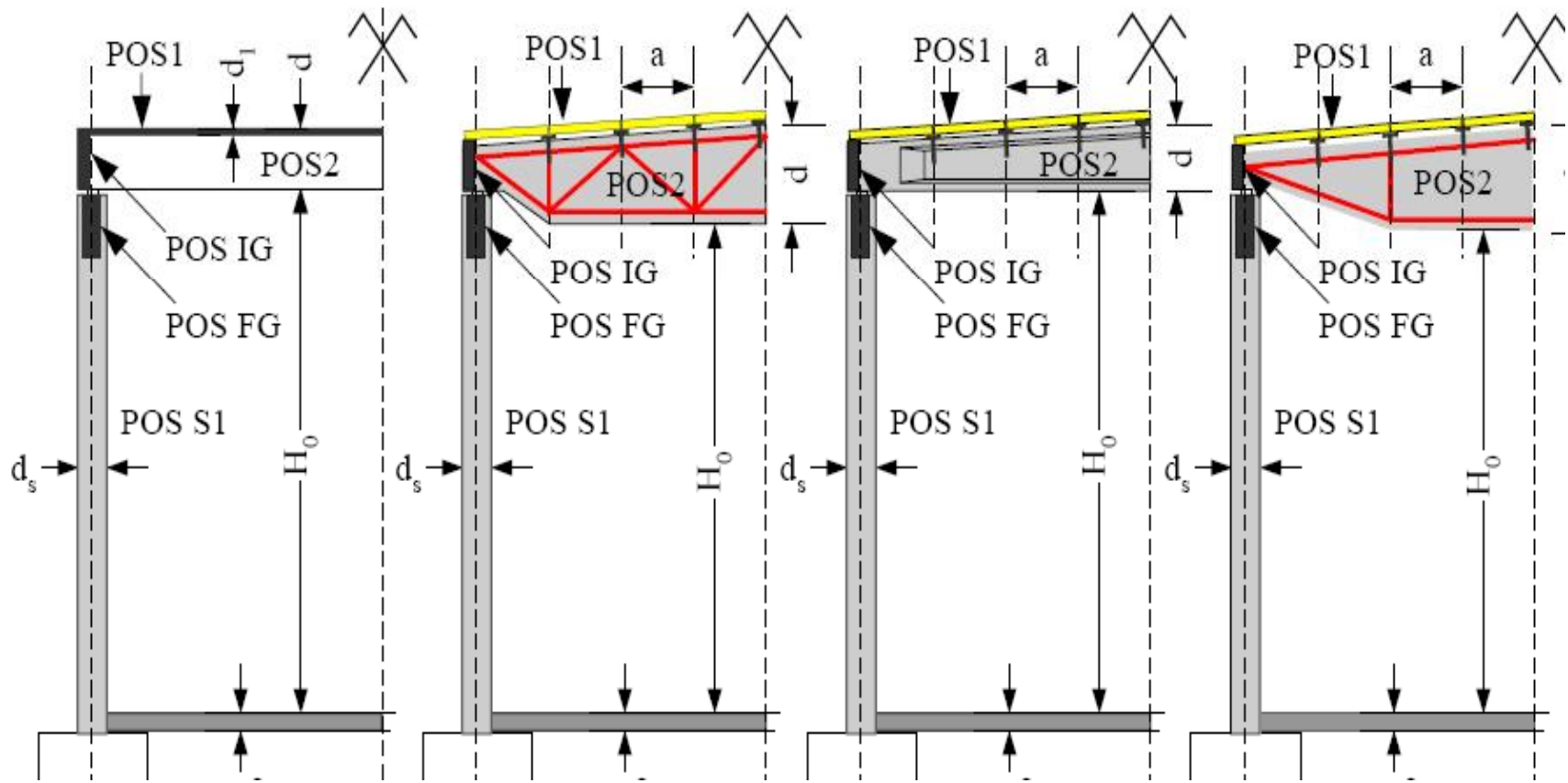

Nosač sa zatregom – Plan oplata i armature

Plan oplata R=1:25

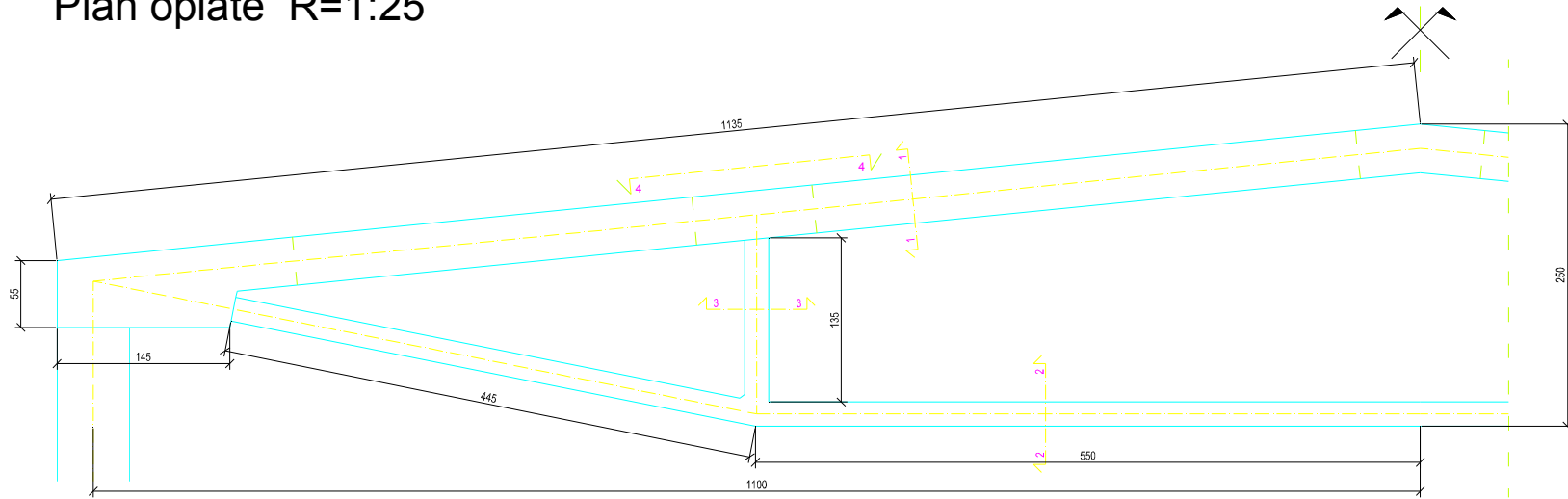

Plan armature R=1:25

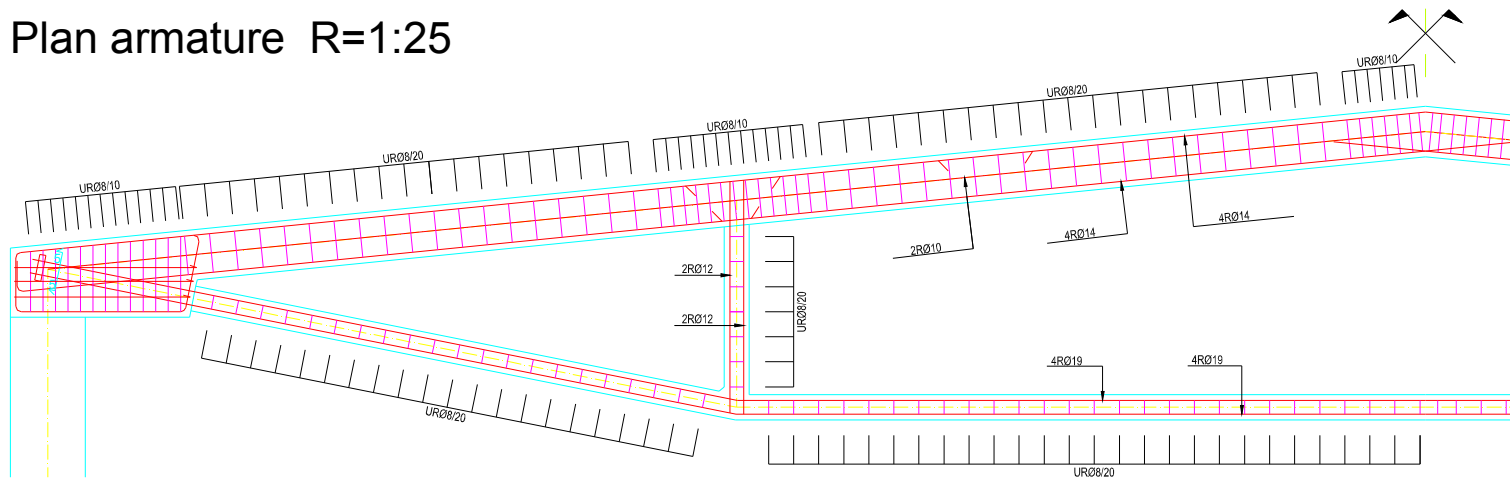

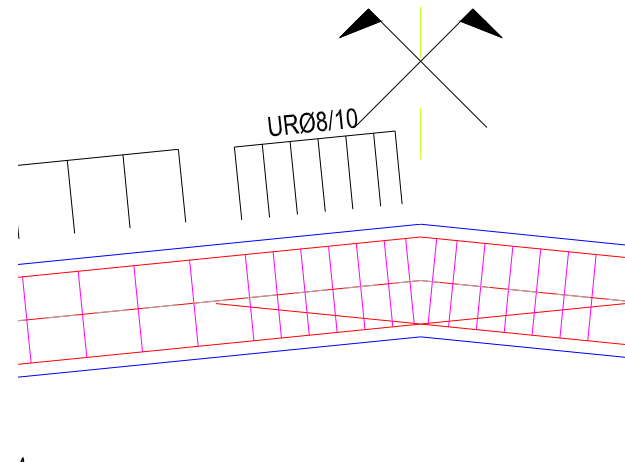
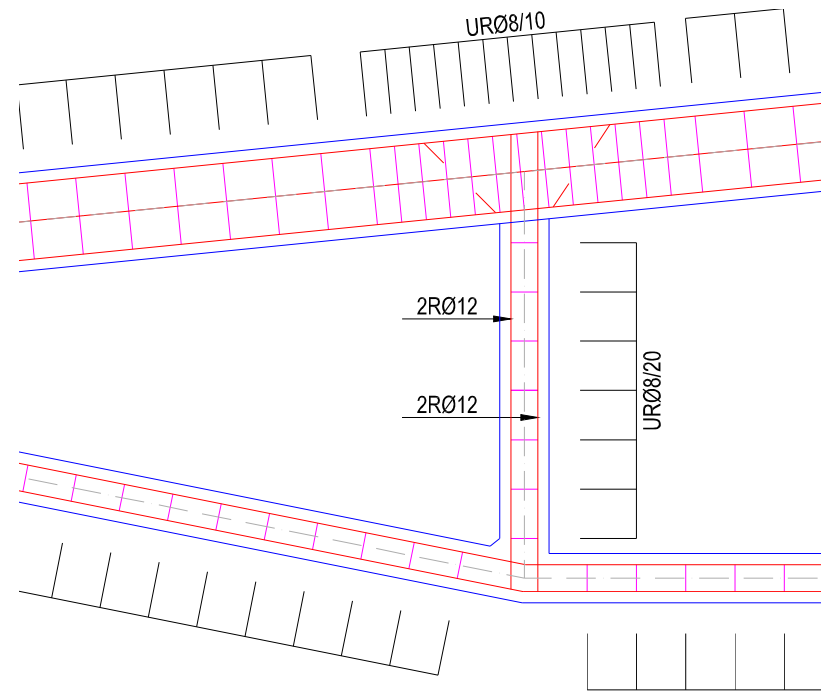
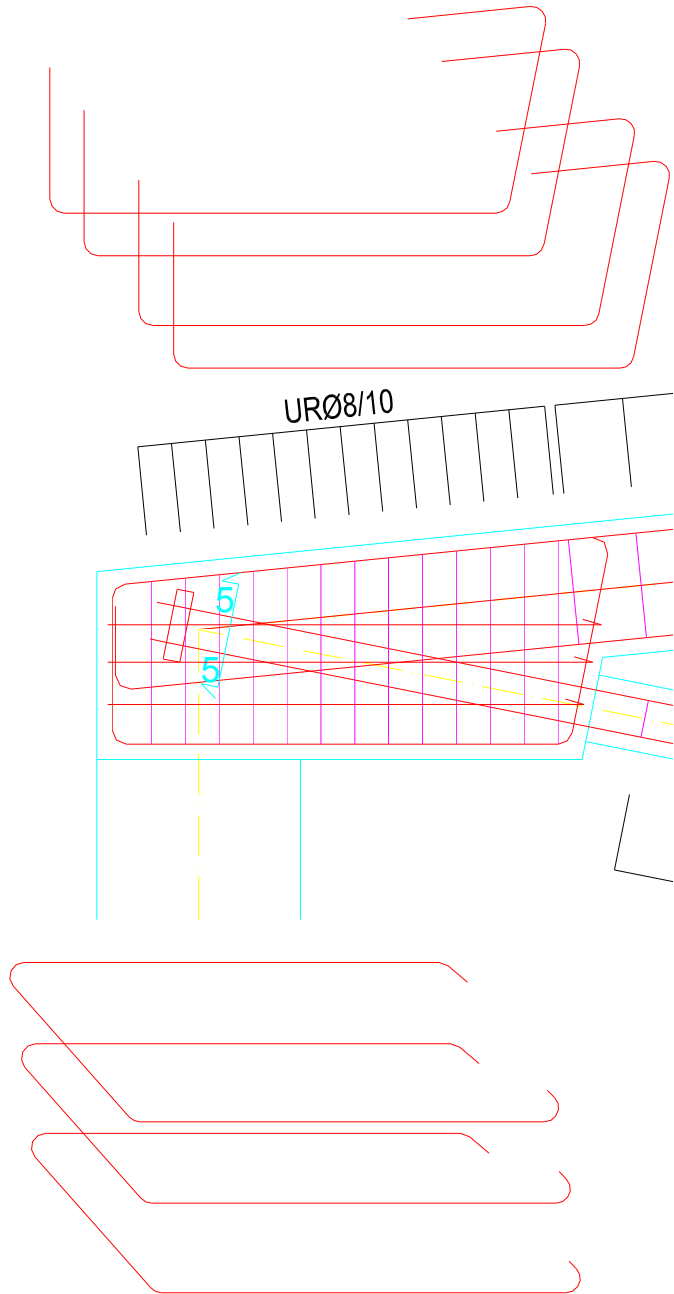

Presek 1-1

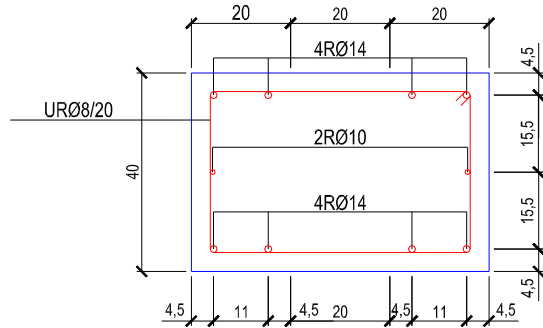

Presek 2-2

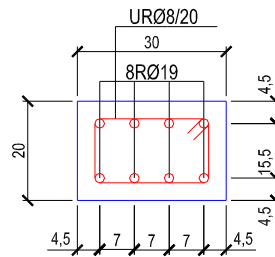

Presek3-3

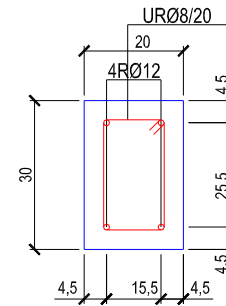

presek 4-4

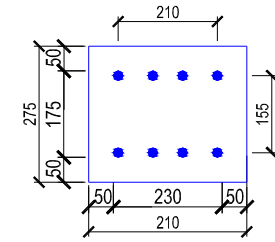

Varijanta:

Presek 1-1

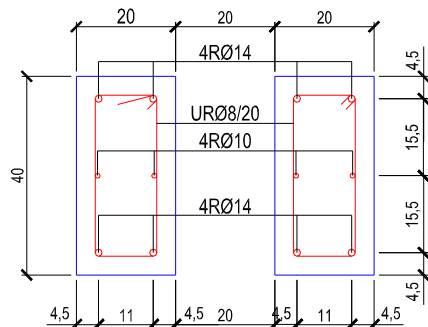

presek 5-5

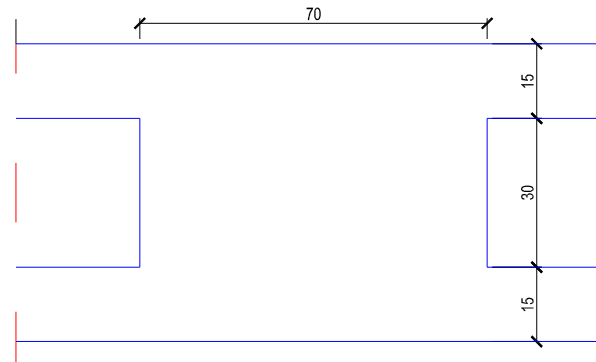

Glavni nosač - rešetka

Plan oplate rešetkastog glavnog vezaca R=1:25

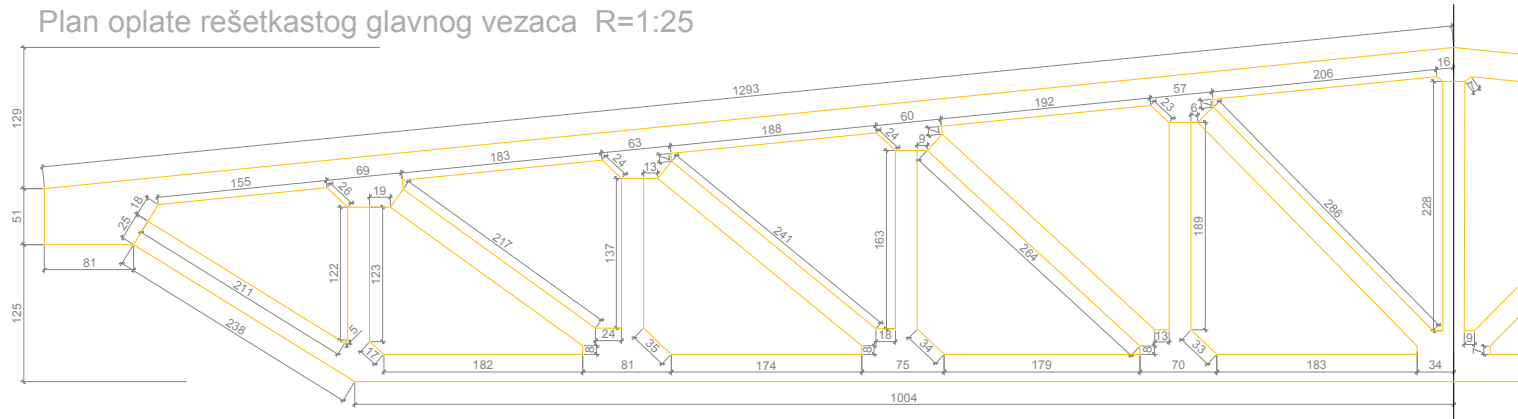

Plan armature rešetkastog glavnog vezaca R=1:25

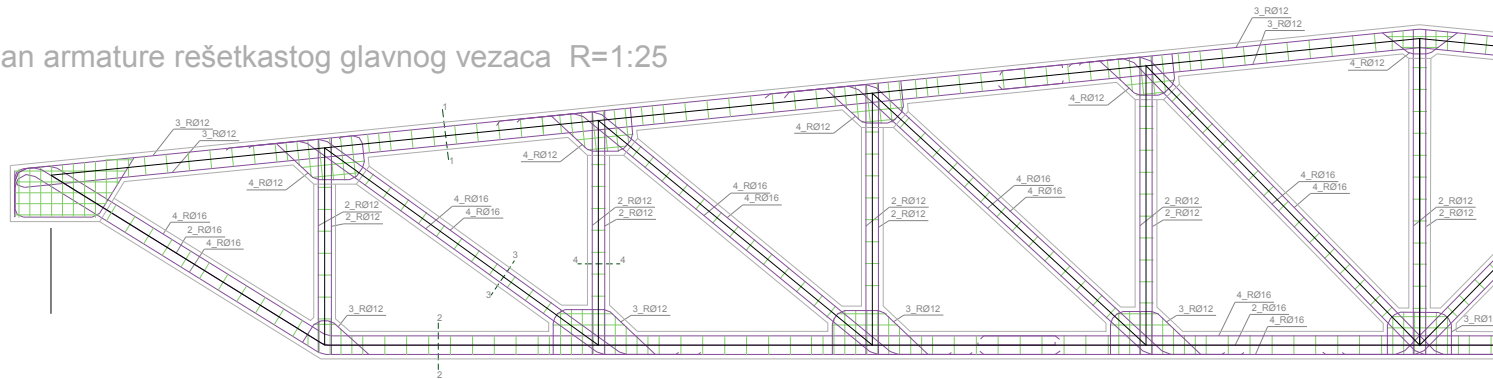

Sistemske dužine R=1:50

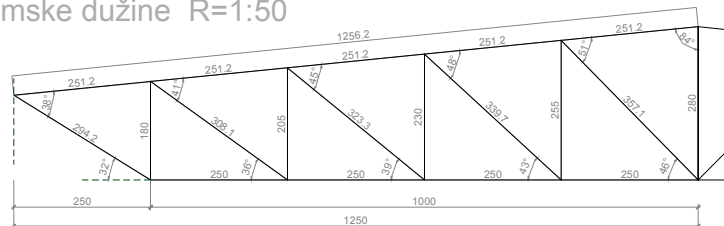

Gornji pojas, presek 1-1 R=1:10

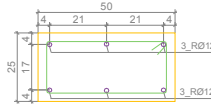

Donji pojas, presek 2-2 R=1:10

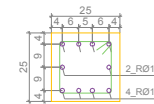

Dijagonale, presek 3-3 R=1:10

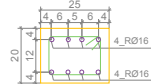

Vertikale, presek 4-4 R=1:10

